



Description

The Series BNS33 coded-magnet sensors are designed for use as a safety interlock switch on movable machine guards/articulating robot arms. Each sensor set consists of a multiple reed switch unit and a coded-magnet actuator. The reed switches, wired in series, will only close in the presence of their matched magnetic field array.

Both switch and magnet assemblies are sealed to IP67 (submersible) standards (IP69K for BNS33S). Their tamper-resistant design prevents bypassing with a simple magnet or improperly coded magnetic field. In addition, the BNS module features an optional built-in LED display of switch status, and a 1-meter long prewired pigtail to assure sealing integrity.

Operation

The reed switch assembly is typically mounted to a stationary portion of a guard structure, with the coded-magnet assembly mounted to the movable element of the machine guard. When the guard is closed, and the matched magnetic field aligns with the reed switch unit, the switches will close. When the guard is open, or the required magnetic-field array is not properly aligned with the reed switch assembly, the sensor output will remain “off.”

Typical Applications



The sealed, compact BNS33 is ideal for use on movable machine guards in hostile environments or where space is limited. Typical applications include food processing equipment, chemical processing equipment, woodworking machinery, packaging machinery, and articulating robot arm rest position sensing.

Features & Benefits

- **Compact size** ... ideal for limited space applications.
- **Sealed for submersibility** ... assures long-term reliability in the most hostile environments.
- **Tamper-resistant** ... cannot be bypassed with simple magnets.
- **Rugged, corrosion-resistant housing** ... tolerates most industrial environments.
- **Integral LED status indicators** ... facilitate easy installations and provide visual indication of switch status.
- **Shock and vibration tolerant** ... designed to withstand mechanical abuse.
- **Satisfy EN954, Category 1, 3, or 4** ... when used with appropriate Series AES safety controllers.
- **Optional high-strength field coded-magnets** ... extends sensing range to 10mm.
- **Units available with M8 quick-connect.** (Please consult factory).
- **Available stainless steel housing (BNS33S)** ... ideal for the food industry.

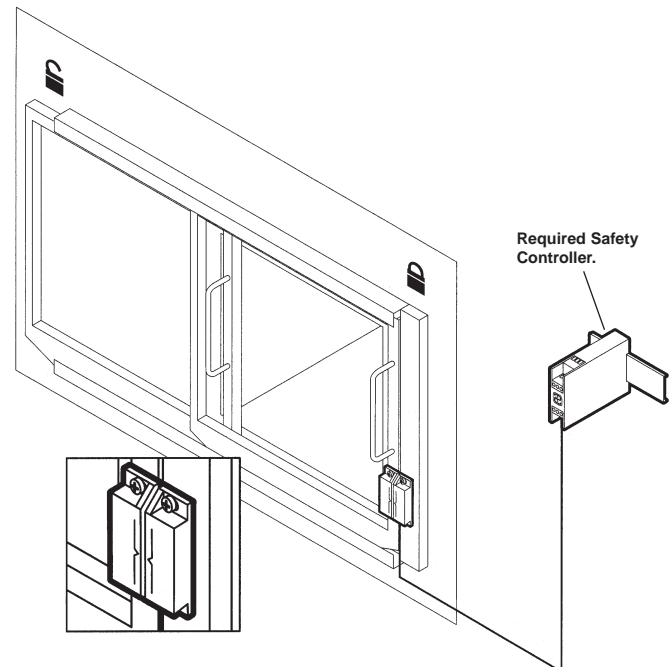

***Important Note:** Series BNS coded-magnet sensors are for use in safety applications only when used with a SCHMERSAL Series AES safety controller. (Please see selection chart on Page 163.)



USE WITH ANY OTHER SAFETY CONTROLLER MAY DAMAGE SENSOR AND/OR VOID WARRANTY.

BNS33 AVAILABLE MODELS AND ACCESSORIES

AVAILABLE STANDARD MODELS

(Please order BPS33 or BPS33-2326 magnet separately)

Part Number	Contact Configuration*	Maximum Contact Rating	Description
BNS33-11z**	1 NO & 1 NC	100VAC/DC (400mA)	Multiple reed switch assembly with 1-meter prewired pigtail
BNS33-12z***	1 NO & 2 NC		
BNS33-11zG**	1 NO & 1 NC	24VDC (10mA)	Multiple reed switch assembly with 1-meter prewired pigtail and built-in LED display
BNS33-12zG***	1 NO & 2 NC		
BNS33-12z-2187**	1 NO & 2 NC	120VAC/DC (250mA)	Multiple reed switch assembly with 1-meter prewired pigtail
BNS33S-12z** <i>New!</i>	1 NO & 2 NC	100VAC/DC (250mA)	Multiple reed switch assembly with 1-meter prewired pigtail and stainless steel enclosure
BNS33S-12zG** <i>New!</i>	1 NO & 2 NC	100VAC/DC (250mA)	Multiple reed switch assembly with 1-meter prewired pigtail and stainless steel enclosure
BPS33	N/A	N/A	Coded-magnet actuator (5mm sensing distance)
BPS33-2326	N/A	N/A	Coded-magnet actuator (10mm sensing distance)
BPS33S <i>New!</i>	N/A	N/A	Stainless steel coded-magnet actuator
BNS33-11z-ST**	1NO & 1NC	60VAC/DC (400mA)	Multiple reed switch assembly with M8x1 quick-connect
BNS33-11zG-ST**	1NO & 1NC	24VDC (10mA)	
BNS33-12z-ST***	1NO & 2NC	60VAC/DC (400mA)	
BNS33-12zG-ST***	1NO & 2NC	24VDC (10mA)	

AVAILABLE ACCESSORIES

Part Number	Description
BN31/33	Shim plate for mounting reed switch assembly on ferrous material
M8ST-2M	Straight quick-connect with 2M cable
M8ST-5M	Straight quick-connect with 5M cable
M8ST-10M	Straight quick-connect with 10M cable
M8ST-15M	Straight quick-connect with 15M cable
M8ST-RA-2M	Right-angle quick-connect with 2M cable
M8ST-RA-5M	Right-angle quick-connect with 5M cable
BNS-SS-CVR	Stainless-steel protective cover for BNS33-xxx
BPS-SS-CVR	Stainless-steel protective cover for BPS33-xxx

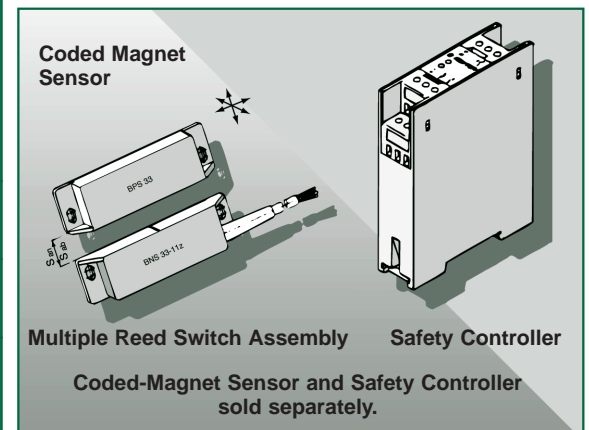

*Contact configuration in presence of BPS33 coded-magnet actuator.

**These models feature isolated contacts.

***These models feature C-form contacts.

Note: Longer prewired cables (3M, 5M, or 10M lengths) available on request. Please consult factory.

Note: SPEZ-2237 for sliding doors is available for BNS33-11z and -11zG only. Contact factory for more information.

BNS33 TECHNICAL DATA

MECHANICAL SPECIFICATIONS

Housing	Fiberglass reinforced thermoplastic
Switching Distance "S" *	"On": 5mm (0.2") "Off": 15mm (0.6") "On": 8mm (0.3") (For BNS33S only) "Off": 18mm (0.7") (For BNS33S only)
Degree of Protection	IP67 (BNS33S: IP69k)
Operating Temperature	-13°F to +158°F (+178°F for BNS33S)
Operating Principle	Magnetic
Shock Resistance	30g/11ms
Vibration Resistance	10 to 55 Hz, amplitude 1mm
Conformity to Standards	CE, UL, CSA VDE 0470 Part 1 IEC 529/EN60529

*Without ferromagnetic material in vicinity of switch or magnet. The proximity of ferrous material may affect switching distances.

ELECTRICAL SPECIFICATIONS

For electrical ratings see page 139	
Type Connection*	1 meter long LiYY4* 0.25mm ² (23AWG) pre-wired pigtail. M8x1 quick-connect for versions with "ST" suffix

*Longer prewired cables available on request. Please consult factory.

BPS33 MISALIGNMENT ALLOWANCE

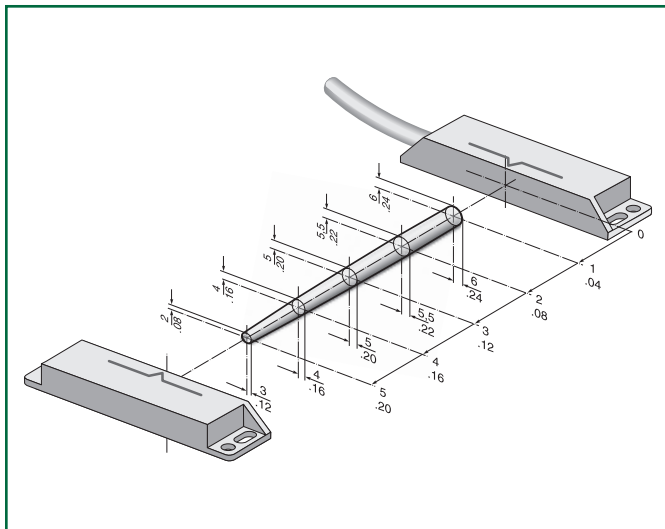

BNS33S MISALIGNMENT ALLOWANCE

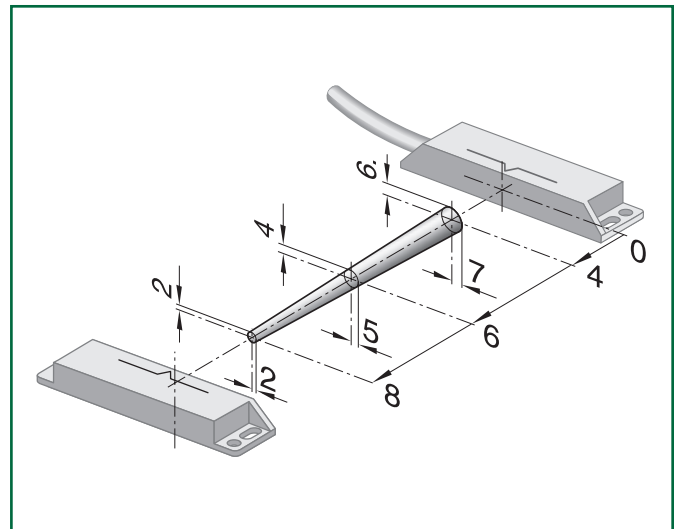

BNS33 TECHNICAL DATA

DIMENSIONS

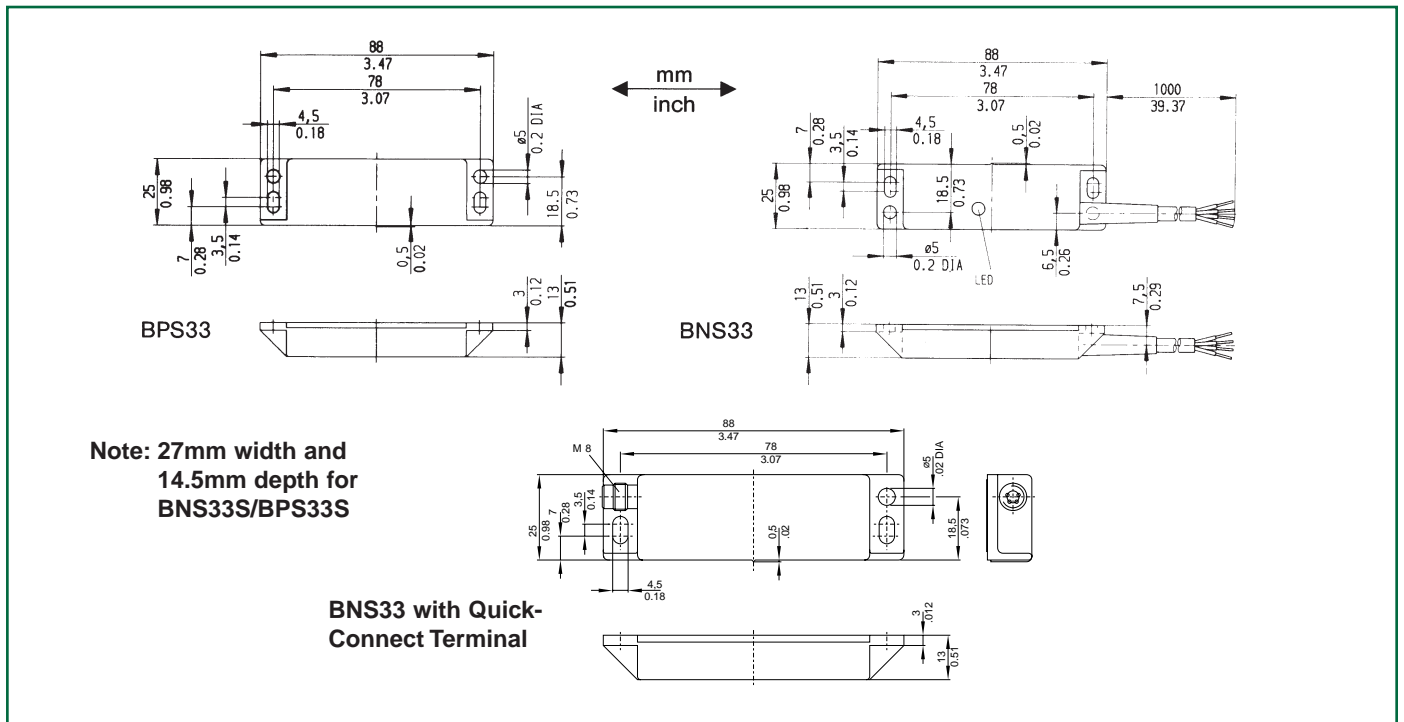

Note: BNS33 reed switch assemblies should be mounted at least 50mm (2") apart.

WIRING DETAILS

