

SERIES CSS 180

Pulse-Echo Based Non-Contact Safety Sensor



Description

The CSS 180 non-contact, electronic safety sensor is designed for application in safety circuits and is used for monitoring the position of movable safety guards. In this application the safety sensor monitors the closed position of hinged, sliding or removable guards with the aid of a coded actuator.

The CSS 180 Safety Sensor fulfills the requirements for proximity devices with defined behavior under fault conditions according to EN 60947-5-3 with the classification PDF-M (self-monitoring).

Operation

The CSS 180 Safety Sensor and CST 180 actuator are a matched pair. As the actuator approaches the sensor, the sensor excites the actuator at a predetermined resonant frequency and the reads back the actuator oscillation. The sensor evaluates the actuator frequency and its distance to the actuator.

Identification of the actuator is interpreted as a closed guard by the safety sensor, and the safety outputs are enabled.

The safety sensor is a dual channel design with two short-circuit proof, safe PNP outputs, each of which can switch up to 500 mA. Due to continuous internal function tests and the monitoring of the safety outputs, a number of CSS 180 Safety Sensors can be wired in series without detriment to the control category. Series wired safety sensors continue to fulfill the requirements of Control Category 4 according to EN 954-1.

Typical Applications

The sealed, compact units are ideal for use on movable machine guards where multiple guard monitoring on a machine is required, and/or where hostile environments exist. Typical applications include printing machinery, textile machinery, paper converting equipment, material handling systems, packaging machinery, chemical processing equipment, and woodworking machinery.

Features & Benefits

- **Non-contact sensing** ... for long term reliability.
- **Sealed for moisture protection** ... ideal for most hostile environments.
- **Tamper-resistant** ... frequency-matched sensor and actuator required for operation.
- **Integral LED diagnostic indicators** ... facilitate easy installation and troubleshooting.
- **Integral self-monitoring** ... satisfy requirements of Safety Control Category 4. *See note below.
- **Designed for “daisy chaining”** ... up to 200m.
- **Dual PNP 500mA safety outputs** ... for application versatility.

AVAILABLE MODELS AND ACCESSORIES (Accessories Ordered Separately)

Model Number	Description
CSS-8-180-2P-E-L	End or single device with pre-wired cable
CSS-8-180-2P+D-E-L	End or single device with diagnostic output, pre-wired cable
CSS-8-180-2P-Y-L	Series device with double pre-wired cable
CSS-8-180-2P+D-M-L	Series device with diagnostic output, pre-wired cable
CST-180-1	Actuator
CSA-M-1	Magnetic latch
H-18	Mounting clamp

Sensors available with M12 cable connector – Add **ST** after L in catalog number

Safety Control Module Requirements

Dual-channel safety inputs, suitable for PNP semiconductor outputs. The internal function tests of the sensor cause the outputs to periodically switch off for a millisecond. This must be tolerated by the control module. The following SCHMERSAL safety control module is recommended for this application: SRB 301 LCB

*Note: A safety control module may be required for reset function and/or feedback monitoring functions, as well as increased output current requirements.

SERIES CSS 180 TECHNICAL DATA

MECHANICAL SPECIFICATIONS

Housing	Glass fiber reinforced thermoplastic	
Degree of Protection	IP67	
Switching Distance	8mm (Nominal) 7.0mm to 9.5mm (Maximum)	
Operating Temperature	-25°C to +55°C	
Storage Temperature	-25°C to +85°C	
Hysteresis	≤ 0.5mm	
Repeatability	≤ 0.2mm	
Response Time	≤ 30ms	
Vibration Resistance	10-55Hz, amplitude 1mm	
Shock Resistance	30g/11ms	
Conformity to Standards	CE	BG
	EN 60947-5-3	UL
	EN 954-1	
	IEC 61508	

ELECTRICAL SPECIFICATIONS

Mode of Operation	Inductive
Rated Operating Voltage	24 VDC -15%/+10%
Rated Operating Current	1.0A
No Load Current	0.05A
Residual Current	≤ 0.5mA
Rated Impulse Withstand Voltage	0.8kV
Rated Insulation Voltage	32 VAC/VDC
Safety Outputs	(2) PNP, short-circuit proof
Safety Output Current	0.5A per output
Safety Output Voltage Drop	Max. 0.5V
Signaling Output	PNP, short-circuit proof
Signaling Output Operating Voltage	Max. 4V below rated operating voltage
Signaling Output Operating Current	Max. 0.05A
Type Interconnection Cable	4x0.5mm ² , 5x0.34mm ² , or 7x0.25mm ²

DIMENSIONS

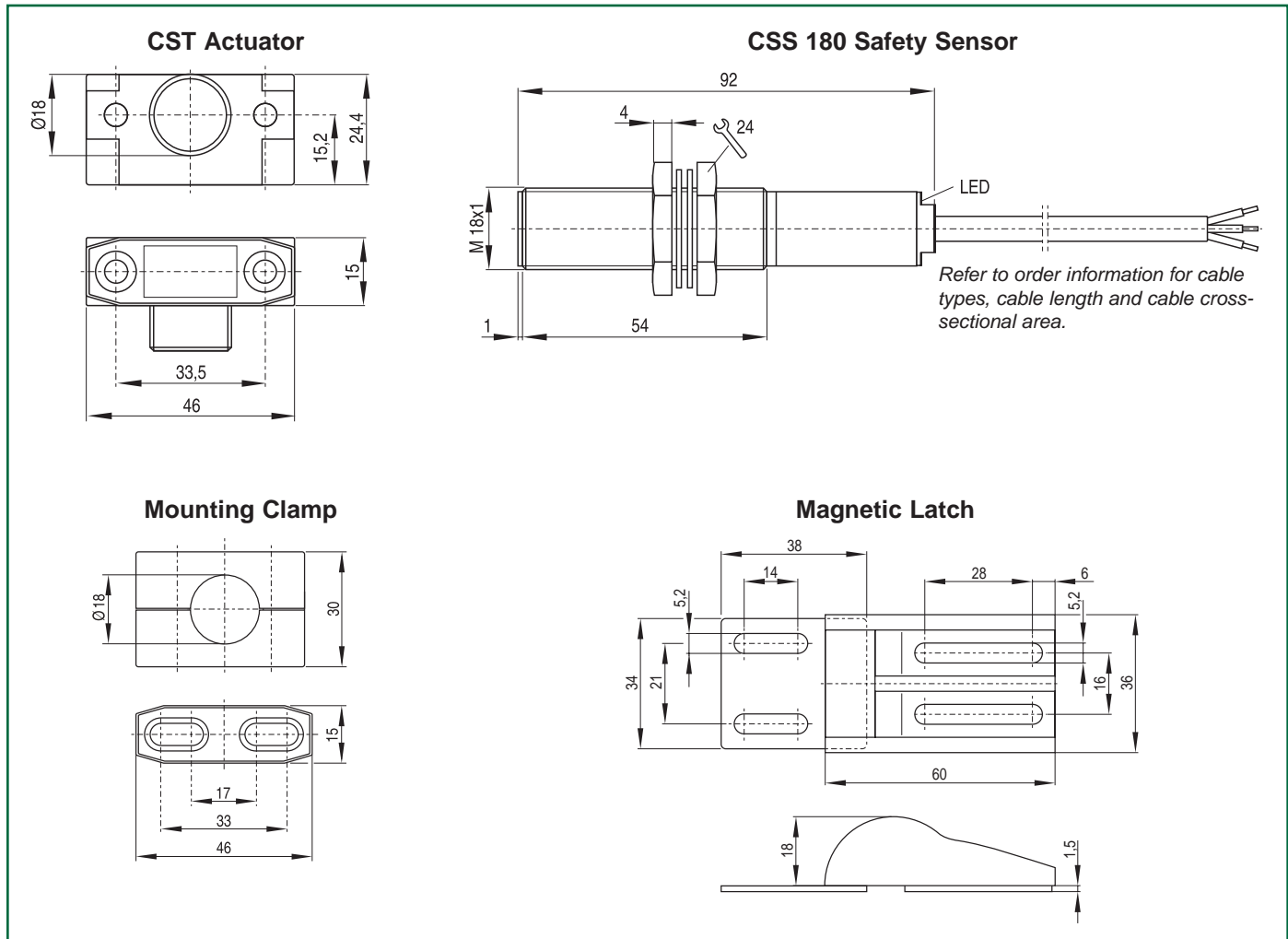

SERIES CSS 180 TECHNICAL DATA

SWITCHING DISTANCES, FLUSH MOUNTING

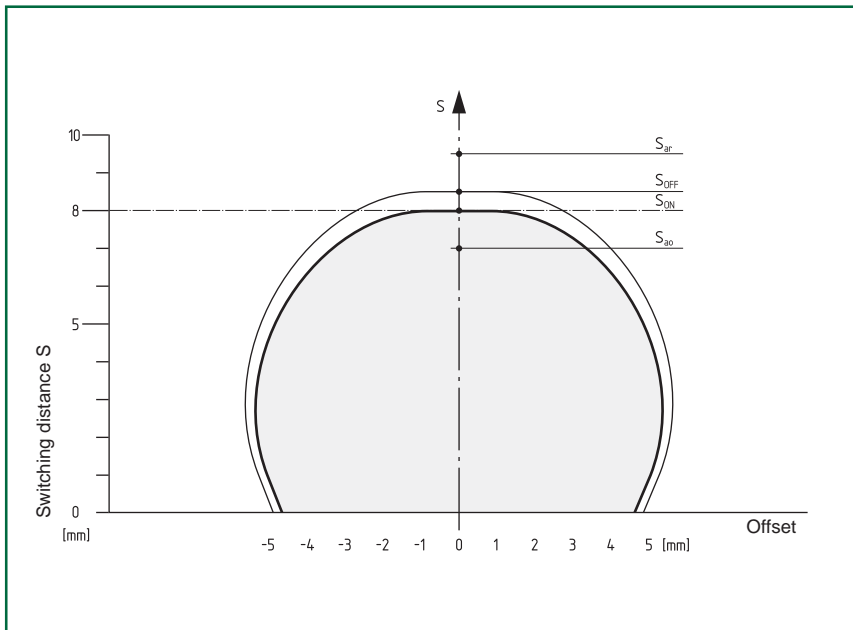

Typical Response Range of the Sensor CSS 180

S_{ON} Switch-on point $S_{ON} < S_H < S_{OFF}$
 S_{OFF} Switch-off point $S_H = \text{Hysteresis area}$

S_{BO} Assured operation point

S_{BR} Assured release point according to EN 60947-5-3

The envelope curves indicate the switch-on and switch-off points of the CSS 180 sensor relative to the target. The maximum offset of the target from sensor axis is approx. 5mm. Flush-mounting of the sensor or actuator reduces the switching distance. Changes in temperature have only a slight effect on the switching points.

Minimum distance between two sensor sets: approximately 100mm

FLUSH MOUNTING OF THE SENSOR CSS 180

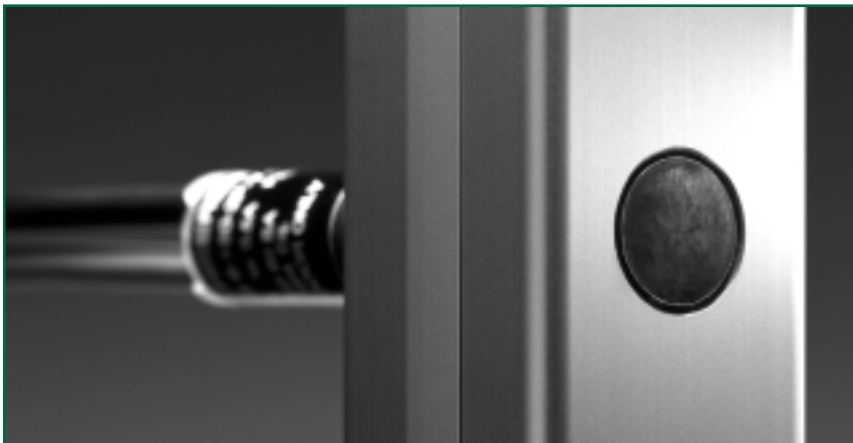

The CSS 180 sensor and the CST 180 actuator can be flush-mounted, however, the switching distance is reduced by approximately 1.5 – 2mm. When the sensor and actuator protrude 2mm out of their mountings the switching distance is not reduced.

Function table of visual diagnostic LED, electronic diagnostic output and safety outputs

Visual diagnostic (red)	Cause of fault	Sensor condition	Diagnostic LED color in sensor end cap	Electronic diagnostic output 24 VDC, 50 mA	Safety outputs
1 pulse	Fault on Output Y1	No target/Power on	Green	0 V	0 V
2 pulses	Fault on Output Y2	Actuated	Yellow	24 V	24 V
3 pulses	Cross-wire short Y1/Y2	Actuated in limit area	Flashes yellow	2 Hz cycle	24 V
4 pulses	Ambient temperature too high	Fault	Flashes red	10 s delay 24 V -> 0 V	1 min delay 24 V -> 0 V
5 pulses	Incorrect or defective actuator				
Continuous	Internal fault				

Six different fault conditions are signalled by the diagnostic LED flashing with predefined pulse sequence or with continuous red light.

SERIES CSS 180 WIRING EXAMPLE 1

Safety Sensors in large systems

The sensors have separate input and output cables. The output of one sensor can be directly wired into the input of the next sensor. The sensor chain can be built up over a length of two hundred meters.

Sensors used:

1 Safety Sensor CSS-8-180-2P-E-L:
This sensor has one output cable. It is designed for the beginning of a chain or for use as a single device.

3 Safety Sensors CSS-8-180-2P-Y-L:
These sensors have separate input and output cables. The output of the

first sensor is wired into the input of the next sensor and so on. This type of sensor can also be used as the first sensor in a chain, if the supply voltage is bridged to the safety inputs.

SERIES CONNECTION OF CSS-8-180

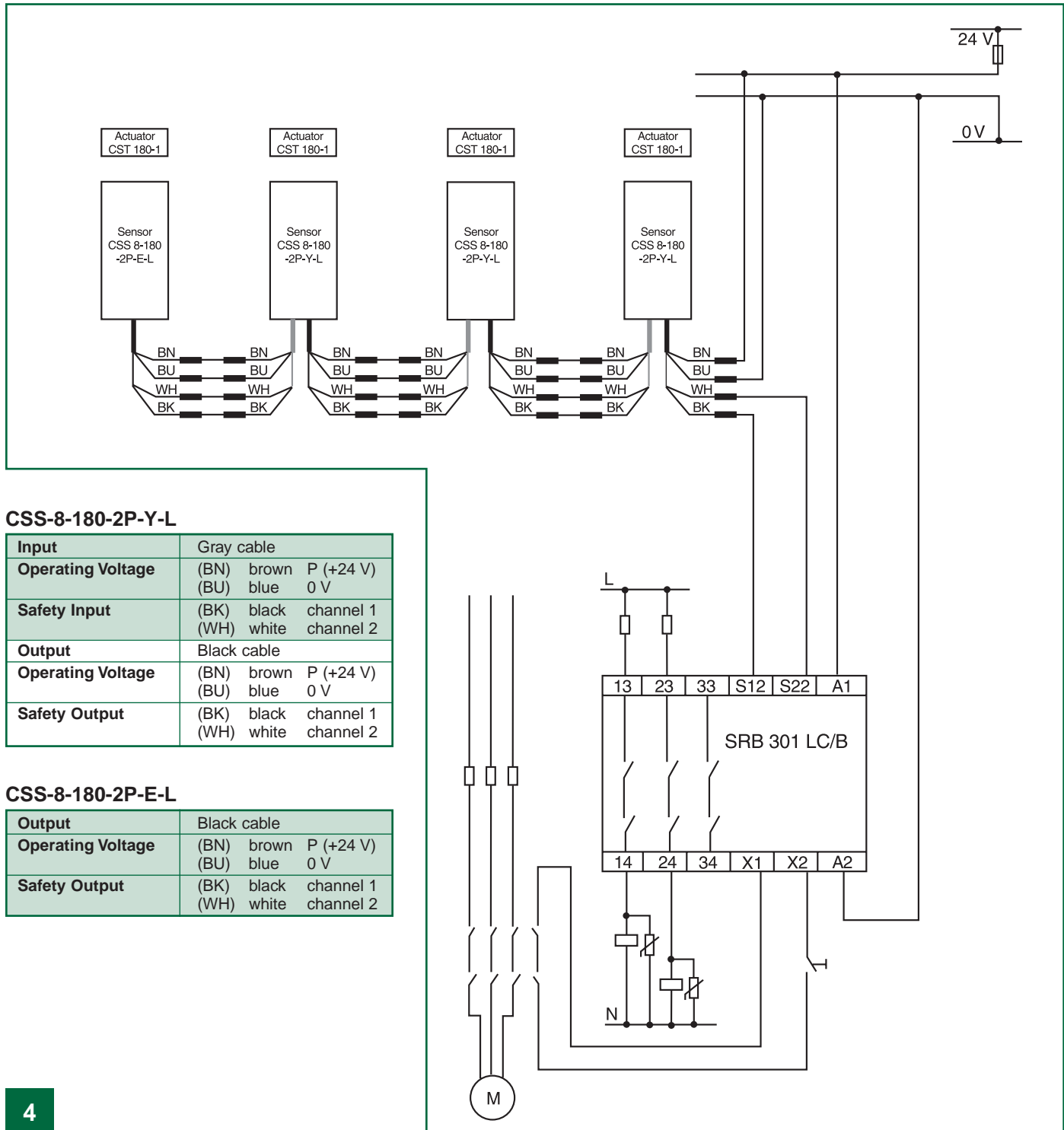

CSS-8-180-2P-Y-L

Input	Gray cable
Operating Voltage	(BN) brown P (+24 V) (BU) blue 0 V
Safety Input	(BK) black channel 1 (WH) white channel 2
Output	Black cable
Operating Voltage	(BN) brown P (+24 V) (BU) blue 0 V
Safety Output	(BK) black channel 1 (WH) white channel 2

CSS-8-180-2P-E-L

Output	Black cable
Operating Voltage	(BN) brown P (+24 V) (BU) blue 0 V
Safety Output	(BK) black channel 1 (WH) white channel 2

SERIES CSS 180 WIRING EXAMPLE 2

Series connection of Safety Sensors CSS 180 in small systems with a centralized control cabinet or wiring via junction boxes.

Sensors used:

1 Safety Sensor CSS-8-180-2P+D-E-L:
This sensor has one output cable. It is designed for the beginning of a chain or for use as a single device.

3 Safety Sensors CSS-8-180-2P+D-M-L:
The inputs and outputs of the sensors are brought out in one cable. The sensors are wired together in series in the control cabinet or in junction boxes.

This type of sensor can also be used as the first sensor in a chain, if the supply voltage is bridged to the safety inputs. For very long sensors chains it is recommended to feed the power supply directly to the first sensor in the chain to avoid excessive voltage drop. The safe outputs of the last sensor in the chain are connected to the safety control module.

If junction boxes are used, standard installation cable can be used for the wiring between junctions. When laid together with control cables in a separated cable channel, shielding is not necessary.

SERIES CONNECTION OF CSS-8-180

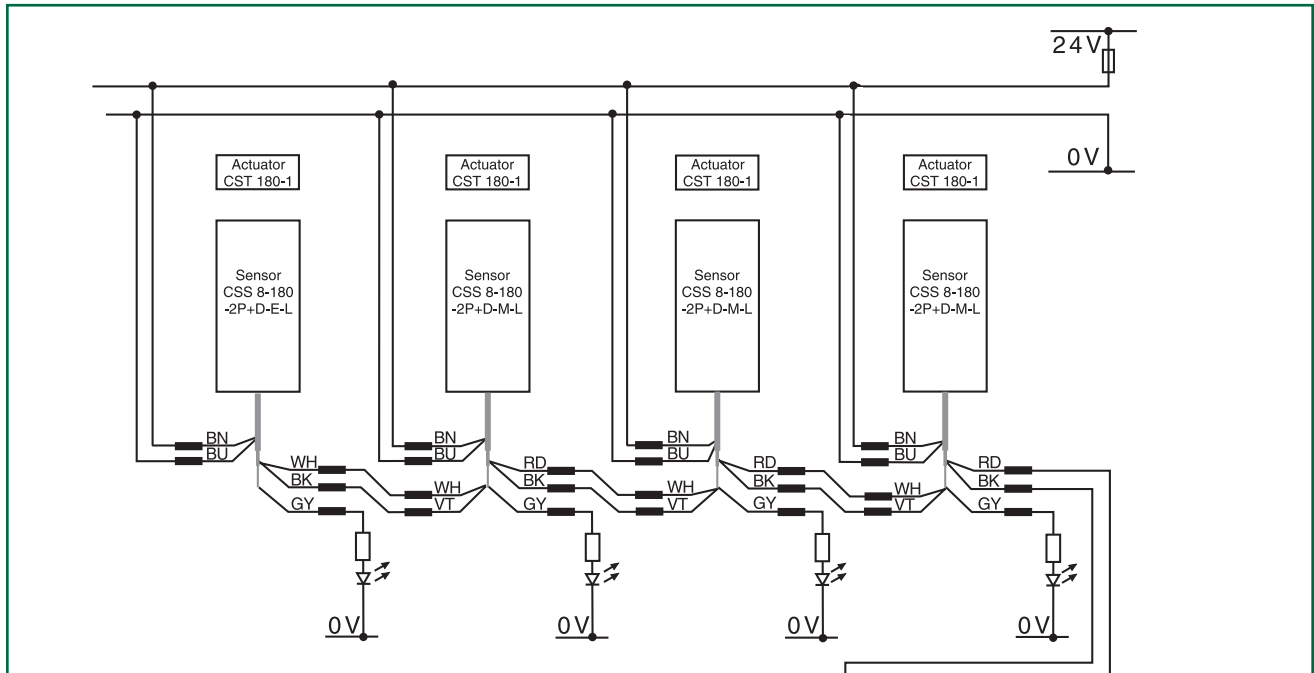

Note: CSS units should be connected to the same regulated power supply.

CSS-8-180-2P+D-M-L

Operating Voltage	(BN) brown	P (+24 V)
	(BU) blue	0 V
Safety Input	(WH) white	channel 1
	(VT) violet	channel 2
Safety Output	(RD) red	channel 1
	(BK) black	channel 2
	(GY) gray	diagnostic output

CSS-8-180-2P+D-E-L

Operating Voltage	(BN) brown	P (+24 V)
	(BU) blue	0 V
Safety Output	(BK) black	channel 1
	(WH) white	channel 2
	(GY) gray	diagnostic output

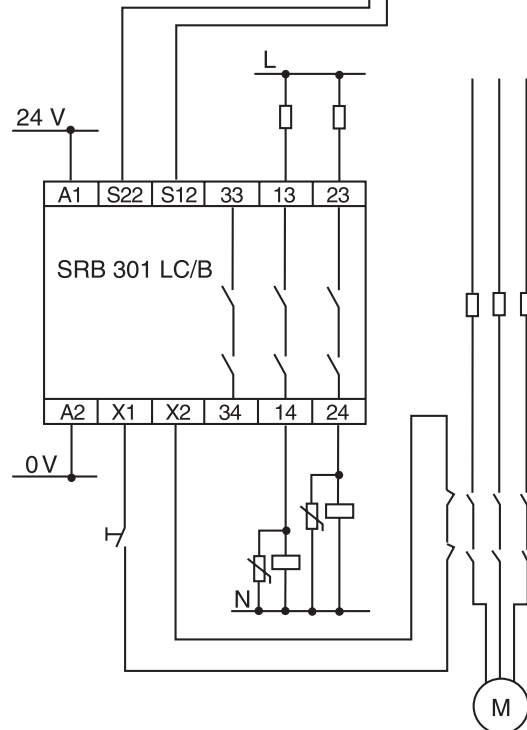

SERIES CSS 180 APPLICATION NOTES

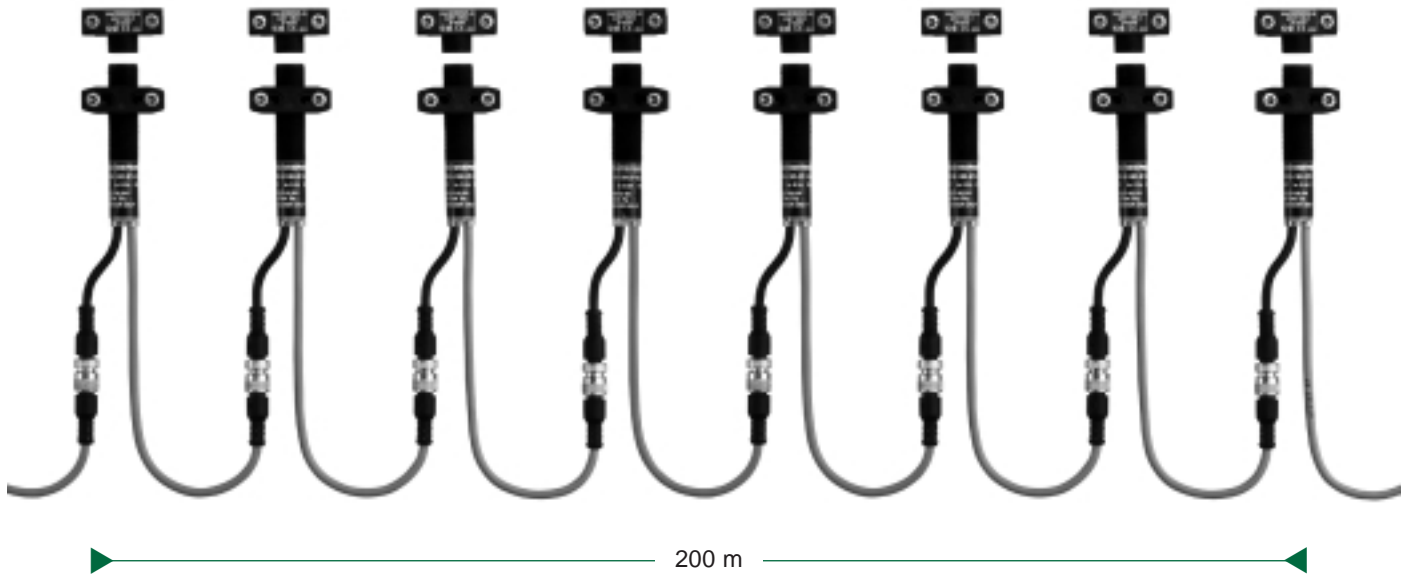

Series wiring of the Safety Sensor CSS 180:

A number of CSS 180 safety sensors can be wired together in series to form a chain. The redundant outputs of the first sensor are in this case wired to the inputs of the second sensor, and so on. The safety sensors in the chain are self-monitoring. The last sensor in the chain provides the two short-circuit proof, PNP outputs each rated at 500mA for further connection to the safety control circuit. The safety requirements according to EN 954-1, Control Category 4 remain fulfilled for the complete chain. Faults within the chain, e.g., a cross-wire short, are detected. This includes faults in the wiring to the safety control monitor, which are also automatically detected.

To make cable routing and interconnection of the safety sensors as simple as possible, a wide range of pre-wired options are available:

For large, extensive guard systems, the Safety Sensor is available with separate input and output cables. The series wired safety sensors can then be built up to a length of over two hundred meters by "daisy chaining" the devices. When the cables are routed in control cable channels, the cables do not need to be shielded. The Y in the part number of the Safety Sensor CSS 180 identifies this version.

For compact systems, or where the control cables are parallel routed to a centralized control cabinet, the input and output leads of the safety sensor are combined in one cable. The series wiring of a number of sensors in this case can be realized in the control cabinet or junction box. This version is identified by an M in the part number of the Safety Sensor CSS 180.

A single cable version is available for individual sensor monitoring and is also suitable for the first sensors in a series. The E in the part number of the Safety Sensor CSS 180 identifies this version.

Note on the total length of a safety sensor chain

The voltage drop over a long sensor chain should be taken into account when planning cable routing.

The exact value of the operating voltage, wire cross-section and cable length, its temperature, the number of sensors connected and the input load of the safety control monitor are all factors that must be considered.

An approximately 200m long sensor chain consisting of six sensors has at 20°C, 100mA input current into the safety control monitor and 0.5mm² cable cross-section, a voltage drop of approximately 1.5V. If junction boxes are installed, a cable with 1.5mm² cross-section should be laid between the junction boxes. When the cables are routed in control cable channels, shielding is not necessary. The cables must however be routed separately from supply and power cables. Local sources of external interference must be properly suppressed.

The power supply for the CSS 180 safety sensors must provide protection against permanent overvoltage. Therefore, SELF or PELF mains supply units are recommended. The maximum permissible fuse protection for the sensor chain is 1.6A gL/gG.

SERIES CSS 180 APPLICATION NOTES



Misalignment in the safety guard can be easily compensated.

The application, mounting and usage

Both the sensor and actuator are small and compact. They can be fitted easily in any position on a machine guard or other object to be monitored. The actuator has two sets of fixing holes for attachment parallel or square to the mounting surface. The sensor can be attached using a mounting clamp (accessory) or with the two M18 nuts (supplied).

If required, both the actuator and the sensor can be flush mounted using the M18 x 1mm standard housing threads.

The sensor and actuator are encapsulated, vibration-resistant and suitable for application in harsh, dusty or dirty environments. They comply to the requirements for the degree of protection IP 67.

Adjustment is simple. A large switching distance and the possibility of also being able to operate the sensor and actuator with an offset enables large tolerances to be accommodated on the safety guard.

The small hysteresis of 0.5mm and a repeatability of 0.2mm result in precise, repeatable switching points throughout its operational lifetime.

The correct functioning of the sensor, a fault in the sensor output, a crosswire short and actuation of the sensor itself by the actuator are signalled by the visual diagnostic 3 color LED. The LED can also be used as an adjustment aid during fitting.

The electronic diagnostic output indicates an actuated sensor. If a sensor is operated near the limit of its switching distance, for example due to the sagging of a guard door, it is detected even before the safety outputs are disabled, and results in an intermittent pulse on the electronic diagnostic output and visual diagnostic LED.

In a similar way, faults which do not immediately compromise the safe operation of the sensor, for example a crosswire short, are signalled as an advance warning. The machine can in this case be run down in a controlled manner.

COMPATIBLE CSS 180 SAFETY CONTROLLERS SRB 301 LCB



ELECTRICAL SPECIFICATIONS

Operating Voltage	24 VDC -15% / +20%, residual ripple max. 10% 24 VAC -15% / +10%, 50/60 Hz
Power Consumption	1.7 W (max.), 1.9 VA
Fuse (Input Power)	Internal glass fuse F1: T 0.25 A
Fuse (Safety Outputs)	6 A Slow-blow (Recommended)
Switching Capacity (Safety Outputs)	230 VAC, 6 A Resistive (inductive with suitable suppressor circuit)
Switching Capacity (Auxilliary Contacts)	24 VDC, 2 A
Application Category	AC 15 / DC 13, EN 60 947-5-1
Pick-up Delay	≤ 30 ms
Drop-out Delay	≤ 50 ms
Contact Type & Materials	AgSnO, self cleaning, positive-guided
Contact Resistance	100 mOhm (max. in new state)
Air Cleaner & Creepage Distance	DIN VDE 0110-1 (04.97), 4 kV/2
Cable Connections	<ul style="list-style-type: none"> Screw terminals for 13 to 20 AWG Stranded or multi-core with wire end ferrule
Terminal Labeling	DIN EN 50 005 / DIN 50 013

TECHNICAL FEATURES

Input Voltage	24 V AC/DC
# Discrete Input Devices Monitored	1 (Single or Dual channel)
Monitored Contact Configuration	N.C. (Dry Contacts) or PNP-switching
Number & Type Safety Outputs	3 N.O. (Dry Contacts)
Number & Type Auxilliary (Non-Safety or Signalling Output)	1 N.C. (Dry Contacts)
Typical Input Devices Monitored	<ul style="list-style-type: none"> E-stops (N.C.) Interlock switches (N.C.) Devices with PNP semi-conductor outputs
Type of Reset (Selectable)	<ul style="list-style-type: none"> Manual (24 V Leading Edge) Automatic
Feedback Monitoring	Yes
LED Displays	Green LEDs for: <ul style="list-style-type: none"> K1 (safety relay 1) K2 (safety relay 2) Ui (voltage beyond internal fuse) U_s (voltage at input terminals)
Conformity to Standards	UL, CSA, BG (CE-compliant)
Stop Category	0
Safety Control Category Rating Per EN 954-1	4

MECHANICAL SPECIFICATIONS

Dimensions (W x H x D)	22.5mm x 100mm x 121mm (0.9" x 3.9" x 4.75")
Ambient Operating Temperature Range	-25°C to +45°C (-13°F to +113°F)
Mechanical Life Expectancy	>10 ⁷ switching cycles
Weight	230 gm (0.5 lbs.)
Mounting	DIN rail (35mm)

Terminal Connections For Use With CSS 180

