



### Description

The CSS 34 non-contact, electronic safety sensor is designed for application in safety circuits and is used for monitoring the position of movable safety guards. In this application the safety sensor monitors the closed position of hinged, sliding or removable guards with the aid of a coded actuator.

The CSS 34 Safety Sensor fulfills the requirements for proximity devices with defined behavior under fault conditions according to EN 60947-5-3 with the classification PDF-M (self-monitoring).

### Operation

The CSS 34 Safety Sensor and CST 34 actuator are a matched pair. As the actuator approaches the sensor, the sensor excites the actuator at a predetermined resonant frequency and the reads back the actuator oscillation. The sensor evaluates the actuator frequency and its distance to the actuator.

Identification of the actuator is interpreted as a closed guard by the safety sensor, and the safety outputs are enabled.

The safety sensor is a dual channel design with two short-circuit proof, safe PNP outputs, each of which can switch up to 250 mA. Due to continuous internal function tests and the monitoring of the safety outputs, a number of CSS 34 Safety Sensors can be wired in series without detriment to the control category. Series wired safety sensors continue to fulfill the requirements of Control Category 4 according to EN 954-1.

### Typical Applications

The sealed, compact units are ideal for use on movable machine guards where multiple guard monitoring on a machine is required, and/or where hostile environments exist. Typical applications include printing machinery, textile machinery, paper converting equipment, material handling systems, packaging machinery, chemical processing equipment, and woodworking machinery.

### Features & Benefits

- **Compact size** ... ideal for limited space applications.
- **Non-contact sensing** ... for long term reliability.
- **Four different actuating surfaces** ... for a variety of mounting options.
- **Sealed for moisture protection** ... ideal for most hostile environments. Meets both IP65 and IP67 requirements.
- **Tamper-resistant** ... frequency-matched sensor and actuator required for operation.
- **Integral LED diagnostic indicators** ... facilitate easy installation and troubleshooting.
- **Integral self-monitoring** ... satisfy requirements of Safety Control Category 4. \*See note below.
- **Designed for "daisy chaining"** ... up to 200m.
- **Dual PNP 500mA safety outputs** ... for application versatility.
- **Integrated mounting plate included** ... allows for easy and accurate alignment of sensor and actuator.

### AVAILABLE MODELS AND ACTUATORS (Actuators Ordered Separately)

Model Number	Description
CSS12-34-VDML	Side Actuating surface with diagnostic output
CSS12-34-VDMST	Side Actuating surface with diagnostic output, M12 cable connector
CSS14-34-SDML	Top Actuating surface with diagnostic output
CSS14-34-SDMST	Top Actuating surface with diagnostic output, M12 cable connector
CST34-S-1	Side surface actuator
CST34-V-1	Top surface actuator

Sensors available with a serial diagnostic cable, for use with a PROFIBUS DP network. Please consult factory.

### Safety Control Module Requirements

Dual-channel safety inputs, suitable for PNP semiconductor outputs. The internal function tests of the sensor cause the outputs to periodically switch off for a millisecond. This must be tolerated by the control module. The following SCHMERSAL safety control module is recommended for this application: SRB 301 LCB, SRB 324 ST

\*Note: A safety control module may be required for reset function and/or feedback monitoring functions, as well as increased output current requirements.

# SERIES CSS 34 TECHNICAL DATA

## MECHANICAL SPECIFICATIONS

<b>Housing</b>	Glass fiber reinforced thermoplastic
<b>Degree of Protection</b>	IP65 and IP67
<b>Switching Distance</b>	Top (V) 12mm Nominal 10-15mm (Maximum) Side (S) 14mm Nominal 12-17mm (Maximum)
<b>Operating Temperature</b>	-25°C to +70°C
<b>Storage Temperature</b>	-25°C to +85°C
<b>Hysteresis</b>	1mm
<b>Repeatability</b>	≤ 0.5mm
<b>Response Time</b>	≤ 30ms
<b>Vibration Resistance</b>	10-55Hz, amplitude 1mm
<b>Shock Resistance</b>	30g/11ms
<b>Conformity to Standards</b>	CE BG EN 60947-5-3 UL/CSA EN 954-1 IEC 61508

## ELECTRICAL SPECIFICATIONS

<b>Mode of Operation</b>	Inductive
<b>Rated Operating Voltage</b>	24 VDC -15%/+10%
<b>Rated Operating Current</b>	0.6A
<b>No Load Current</b>	0.1A
<b>Residual Current</b>	≤ 0.5mA
<b>Rated Impulse Withstand Voltage</b>	1 kV
<b>Rated Insulation Voltage</b>	32 VAC/VDC
<b>Safety Outputs</b>	(2) PNP, short-circuit proof
<b>Safety Output Current</b>	0.25A per output
<b>Safety Output Voltage Drop</b>	Max. 0.5V
<b>Signaling Output</b>	PNP, short-circuit proof
<b>Signaling Output Operating Voltage</b>	Max. 4V below rated operating voltage
<b>Signaling Output Operating Current</b>	Max. 0.05A
<b>Interconnection Cable:</b>	Y-UL2517/8xAWG22 (8x0.35mm <sup>2</sup> ), 2m
<b>Connector:</b>	M12x1, 8 pin quick connect

## DIMENSIONS

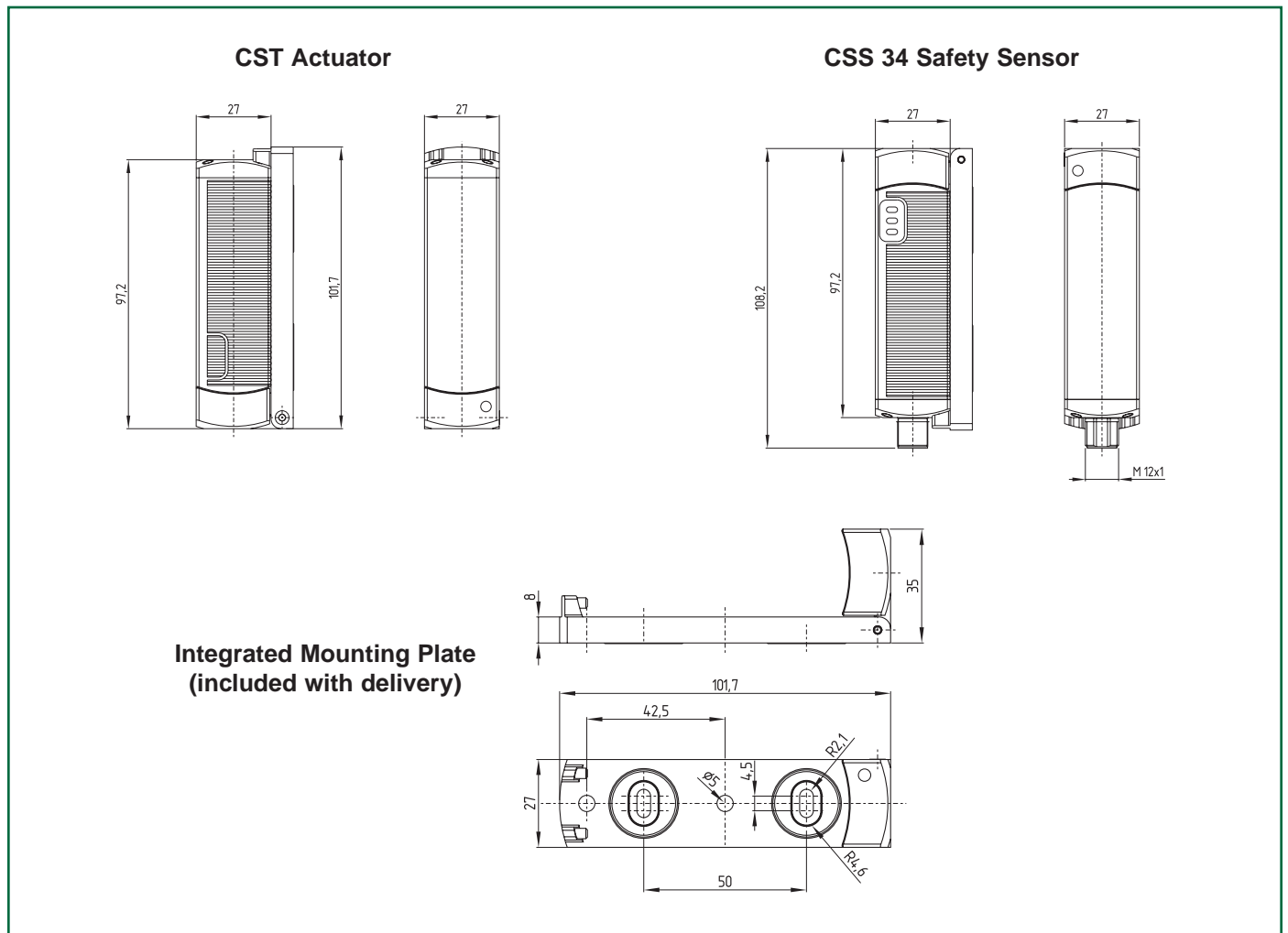

# SERIES CSS 34 TECHNICAL DATA

## SWITCHING DISTANCES

The actuating curves represent the points at which the CSS 34 sensor switches on and off upon the approach of the actuator.

### Legend

- S Switching Distance
- V, V1, V2 Possible misalignment (see drawings at right)
- S<sub>ON</sub> Switch-on point
- S<sub>OFF</sub> Switch-off point
- S<sub>H</sub> Hysteresis area  
S<sub>H</sub> = S<sub>OFF</sub> - S<sub>ON</sub>
- S<sub>ao</sub> Assured operation point
- S<sub>ar</sub> Assured release point (according to EN60947-5-3)

Minimum distance between two sensor sets: approximately 100mm

### Actuation From Side

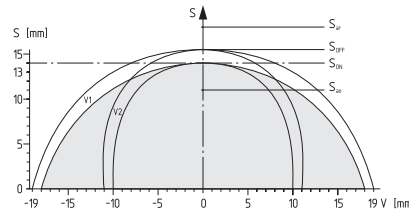

### Actuation From Top

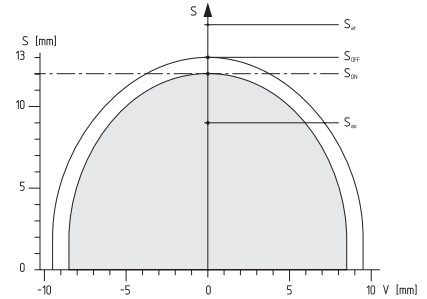

### Sideways Misalignment

Horizontal: Max ±10mm (V2)  
Vertical: Max ±18mm (V1)

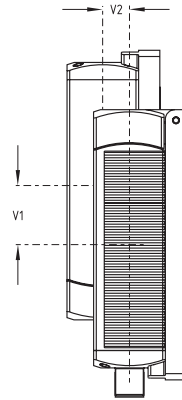

### Top Misalignment

Horizontal: Max ±8.5mm (V)

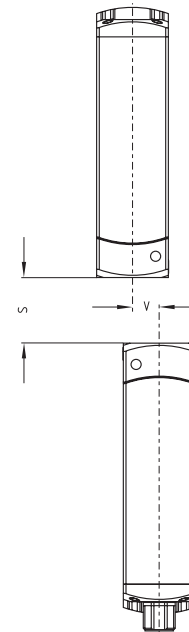

## Function table of visual diagnostic LED, electronic diagnostic output and safety outputs

Visual diagnostic (red)	Cause of fault	Sensor condition	Diagnostic LED color in sensor end cap	Electronic diagnostic output 24 VDC, 50 mA	Safety outputs
1 pulse	Fault on Output Y1	No target/Power on	Green	0 V	0 V
2 pulses	Fault on Output Y2	Actuated	Yellow	24 V	24 V
3 pulses	Cross-wire short Y1/Y2	Actuated in limit area	Flashes yellow	2 Hz cycle	24 V
4 pulses	Ambient temperature too high	Fault	Flashes red	10 s delay 24 V -> 0 V	30 min delay 24 V -> 0 V
5 pulses	Incorrect or defective actuator				
Contin- uous	Internal fault				

Six different fault conditions are signalled by the diagnostic LED flashing with predefined pulse sequence or with continuous red light.

# SERIES CSS 34 WIRING EXAMPLE 1

## Series wiring with single diagnostic output

The supply voltage is wired to both safety inputs of the last sensor of the chain (starting from the safety controller). The safety outputs of the first sensor are wired to the safety controller. The sensor chain can be built up over a length of two hundred meters.

## Sensors used:

Safety Sensor CSS14-34-SDML:

This sensor has one output cable. The output of the first sensor is wired into the input of the next sensor and so on.

## SERIES CONNECTION OF CSS 34

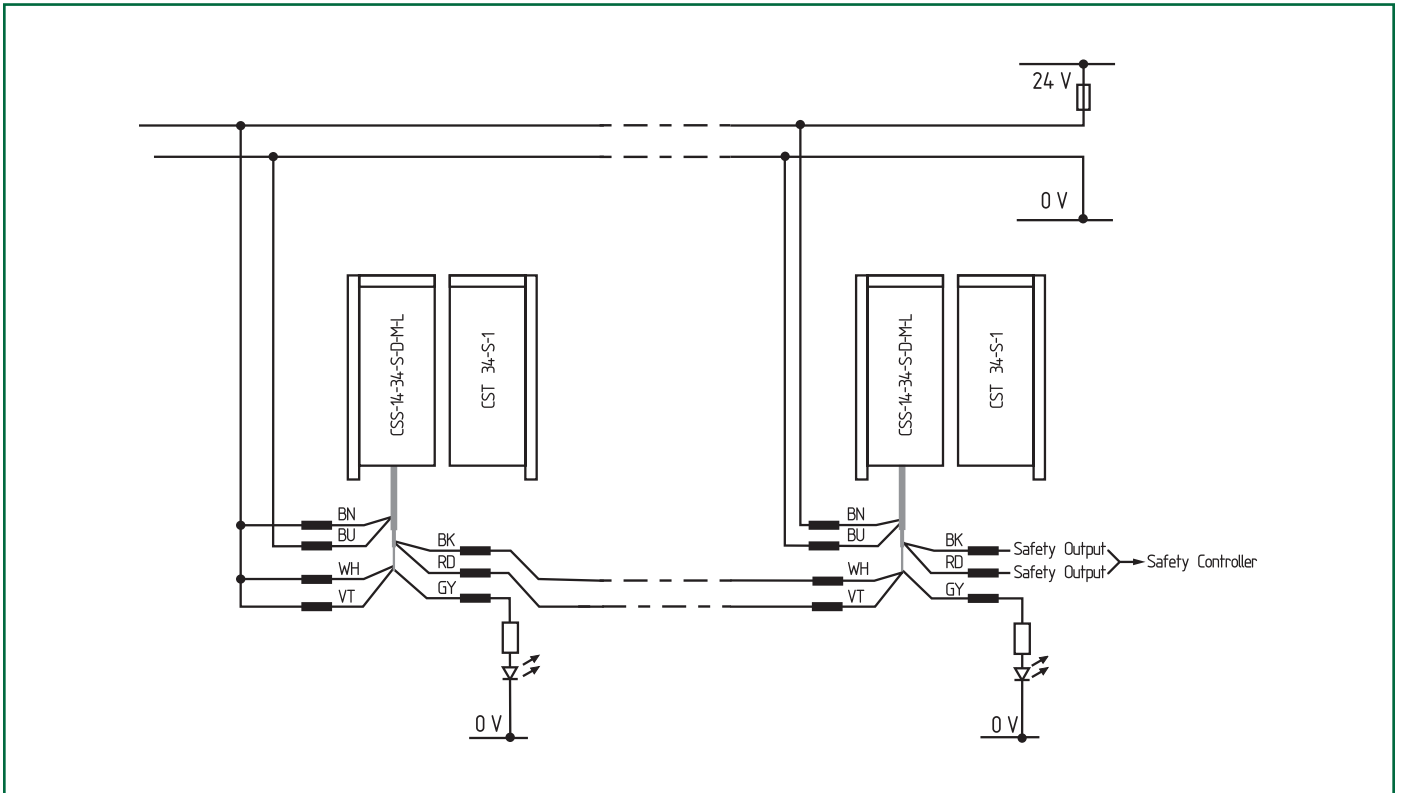

## CSS14-34-SDML

<b>Operating Voltage</b>	(BN) brown	P (+24 V)
	(BU) blue	0 V
<b>Safety Input</b>	(WH) white	channel 1
	(VT) violet	channel 2
<b>Signal Output</b>	(GY) gray	diagnostic
	(PK) pink	nonfunction
<b>Safety Output</b>	(BK) black	channel 1
	(RD) red	channel 2