

HINGED SAFETY INTERLOCK SWITCHES

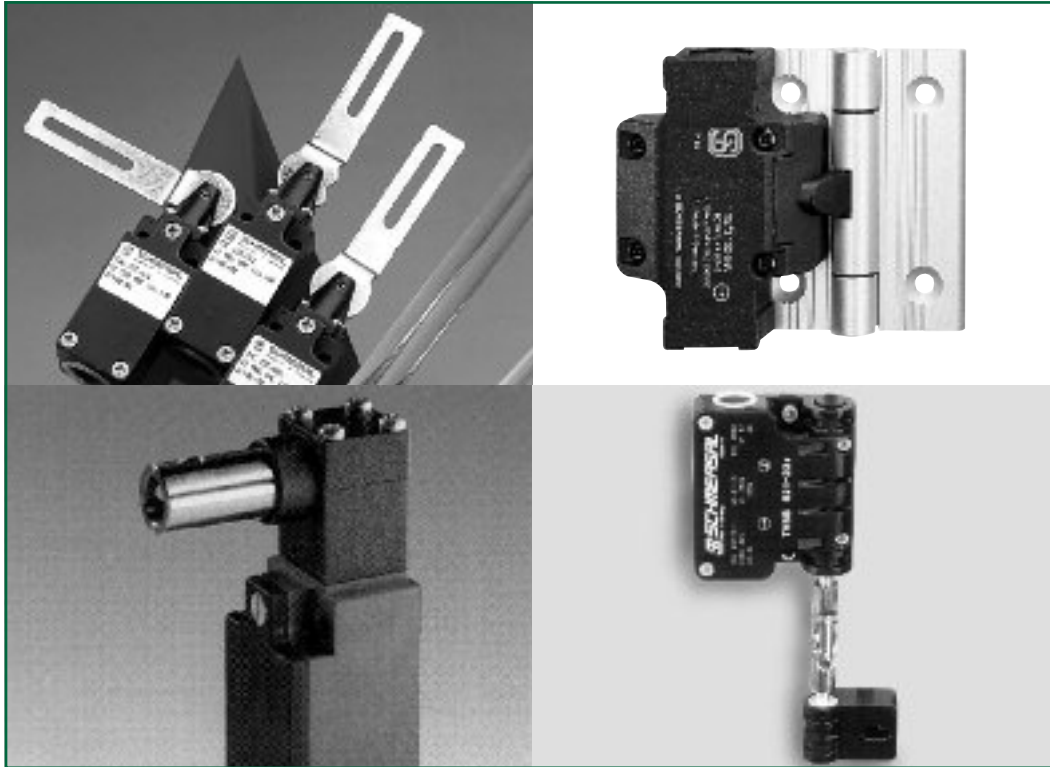

SELECTION GUIDE

| Switch Series | Housing Material | Angular Displacement for Contact Opening | Contact Configurations | Catalog Page |
|------------------|---------------------------------------|--|-----------------------------|--------------|
| New! TESF | Die-cast zinc | Adjustable | 1 NO & 2 NC 2 NO & 2 NC | 210 |
| TESZ | Glass-fiber, reinforced thermoplastic | 4.5° | 1 NO & 2 NC 3 NC | 214 |
| ES95 SB | Glass-fiber, reinforced thermoplastic | 7° | 1 NO & 1 NC 2 NC | 216 |
| TVS335 | Die-cast aluminum, enamel finish | 2° | 1 NO & 1 NC 2 NC | 218 |
| T.C 235 | Die-cast zinc, enamel finish | 4.5° | 1 NO & 1 NC 2 NC 1 NC | 220 |
| T.C 236 | Glass-fiber, reinforced thermoplastic | 4.5° | 1 NO & 1 NC 2 NC 1 NC | 220 |



Description

The TESF Series is designed for use with movable hinged machine guards which must be closed for operator safety. Their tamper-resistant design and positive-opening NC contacts provide a significantly higher level of safety than conventional, spring-driven limit switches or proximity switches often used to monitor hinged guard positions.

Their compact, low-profile design and IP65 rating make them ideal for interlocking hinged safety guards in industrial environments. Designed to mount directly on the hinged guard and its stationary frame, it is easy to install on a wide range of extruded aluminum guard sizes and other guard styles.

Among its unique features is its ability to adjust the switching point in the field to meet specific application requirements.* Once adjusted, the switching point is easily permanently locked to prevent further adjustment by unauthorized personnel. In addition it features top or bottom cable entries, 1 NO or 2 NO and 2 NC contacts, designs suitable for inside- or outside-guard mounting, and the ability to open a full 180°.

*Note: The unit is delivered factory set with a switching point at a 3° opening angle with positive-break occurring at 5°. Please note that with use this factory-set point may increase 2° during lifetime. This should be considered ... especially where finger or hand protection is desired.

Operation

The installed TESF features two integral contact blocks ... each featuring a NO and a NC contacts. NC contacts are positive-opening, while the NO contact(s) may be used for signaling purposes. The electromechanical switch elements are actuated when the hinged guard is opened to the user's desired switching position (angle of opening). At this point the unit's positive-break, normally-closed contacts are forced to open by a direct (non-resilient) actuating mechanism, while the normally-open contacts close. The opening of the positive-break NC contacts ensure circuit interruption and machine stoppage. Machine restart is not possible while the guard remains opened.

Features & Benefits

- **Tamper-resistant** ... integral switch elements and actuator prevent bypassing.
- **“Positive-break” NC contacts** ... ensure circuit interruption when guard is opened to user's desired switching position (angle of opening).
- **User-selectable switching point** ... makes unit suitable for a wide range of applications.
- **Models available for inside-of-guard or front-of-guard mounting** ... for application versatility.
- **Choice of top or bottom cable entry** ... for installation flexibility.
- **Permits wide guard opening** ... up to 180°.
- **Splash-proof design** ... meets IP65 environmental requirements.
- **Slotted mounting holes** ... permit installation to most 30mm to 60mm aluminum profiles.
- **Rugged construction** ... tolerates mechanical abuse and hostile environments.
- **Meets rigid safety standards** ... UL, CSA, & BG (in preparation).

AVAILABLE STANDARD MODELS

(Includes hinge switch assembly and additional hinge)

| Part Number (Contacts) | Description | Type Connections |
|--------------------------------|---|---------------------------------------|
| TESF/O (2NO & 2NC) | For front installation with factory set switching point at 3° | Screw terminals |
| TESF/180 (2NO & 2NC) | For inside installation with factory set switching point at 3° | Screw terminals |
| TESF/U (2NO & 2NC) | For front or inside installation with user adjustable switching point | Screw terminals |
| TESF/ST24.1PE/U (1NO & 2NC) | For front or inside installation with user adjustable switching point | 24VDC Quick disconnect (bottom entry) |
| TESF/ST24.2PE/U (1NO & 2NC) | For front or inside installation with user adjustable switching point | 24VDC Quick disconnect (top entry) |
| TESF/ST24.1PE/O (1NO & 2NC) | For front installation with factory set switching point at 3° | 24VDC Quick disconnect (bottom entry) |
| TESF/ST24.2PE/O (1NO & 2NC) | For front installation with factory set switching point at 3° | 24VDC Quick disconnect (top entry) |
| TESF/ST24.1PE/180 (1NO & 2NC) | For inside installation with factory set switching point at 3° | 24VDC Quick disconnect (bottom entry) |
| TESF/ST24.2PE/180 (1NO & 2NC) | For inside installation with factory set switching point at 3° | 24VDC Quick disconnect (top entry) |
| TESFA/180 (2NO & 2NC) | Hinged interlock with integral fixed-to-movable guard frame alignment aid. For inside installation with factory set switching point at 3° | Screw terminals |
| TESFA/ST24.1PE/180 (1NO & 2NC) | Hinged interlock with integral fixed-to-movable guard frame alignment aid. For inside installation with factory set switching point at 3° | 24VDC Quick disconnect (bottom entry) |
| TESFA/ST24.2PE/180 (1NO & 2NC) | Hinged interlock with integral fixed-to-movable guard frame alignment aid. For inside installation with factory set switching point at 3° | 24VDC Quick disconnect (top entry) |

A 22 mm gap between the door and door frame is required for models with the alignment aid and for inside mount models.

AVAILABLE ACCESSORIES

| Part Number | Description |
|-------------|---|
| TESF/S | Additional hinge assembly (without alignment aid) |
| TESFA/S | Additional hinge assembly (with integral alignment aid) |
| TESF-14 | Switching Point Adjustment Tool |

SERIES TESF TECHNICAL DATA

MECHANICAL SPECIFICATIONS

| | |
|---|--|
| Materials of Construction | Housing & hinge: die-cast zinc Cover: thermoplastic |
| Factory Set Displacement Angle for NC Contact Opening and NO Contact Closing | 3° |
| Degree of Protection | IP65 |
| Maximum Opening Angle | 180° |
| Operating Temperature | -10°F to +148°F |
| Mechanical Life | > 10 ⁶ Operations (minimum) |
| Mechanical Loading Capacity (See dimensional drawings) | F1: 5000 N (110 lbs.) F2: 5000 N (110 lbs.) F3: 2000 N (45 lbs.) |
| Installed Position | Random |
| Operating Rate | 1200 operations/hour (maximum) |
| Shock Tolerance | 30g/18ms |
| Vibration Tolerance | 20g, 10 ... 200 Hz |
| Cable Entry | M16 x 1.5 |
| Maximum Actuation Speed | 180°/0.3 seconds |
| Conformity to Standards | UL, CSA, & BGIA (in preparation) |

ELECTRICAL SPECIFICATIONS

| | |
|--|---|
| Contacts | Silver-nickel, gold-plated |
| Contact Rating | 2A/250 VAC (AC15) 1A/24 VDC (DC13) |
| Contact System | Cross Point System |
| Contact Force | 1N per contact |
| Switching Action | Slow-acting, positive-break NC contacts |
| Short-Circuit Protection | 2.0 A (Slow blow) |
| Rated Impulse Withstand Voltage | 2.5 kV |
| Rated Insulation Voltage | 250 VAC |
| Thermal Rated Current | 2.5 A |
| Rated Operating Voltage | 250 VAC |
| Switching of Small Loads | 5 VDC/1 mA (minimum) |
| Electrical Connections* | Screw terminals for 15AWG maximum stranded wire or 24 VDC quick disconnect: M12 (8 Pole) |



Front installation:
Guard closed



Front installation:
Guard opened through 180°



Inside installation:
Guard closed



Inside installation:
Guard opened through 180°

CONNECTOR PIN CONFIGURATION

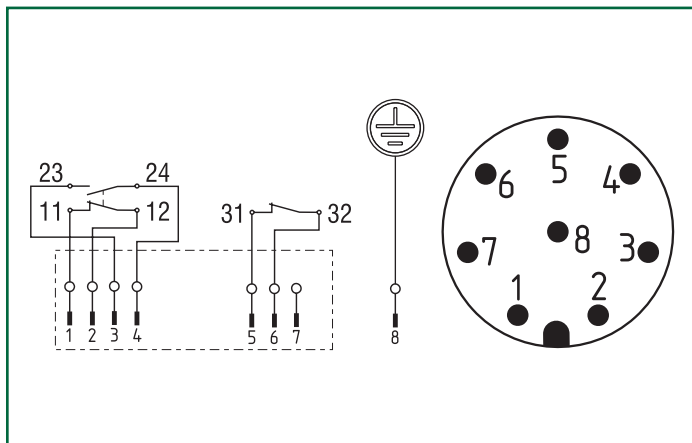

SWITCHING DIAGRAMS & CONTACT SCHEMATICS

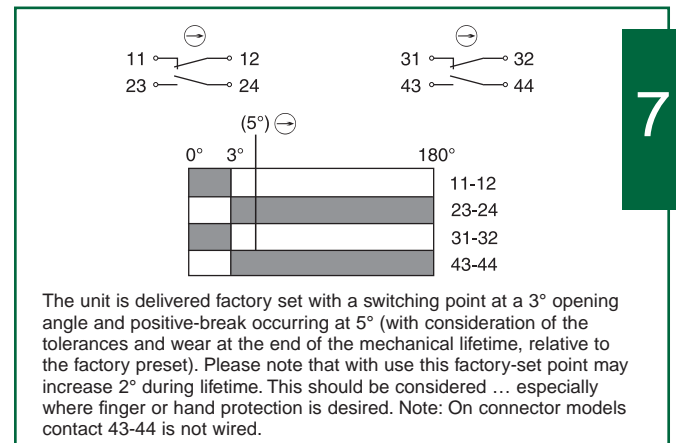

7

SERIES TESF TECHNICAL DATA

DIMENSIONS (SWITCH & HINGE ASSEMBLY SHOWN WITH ALIGNMENT AIDS)

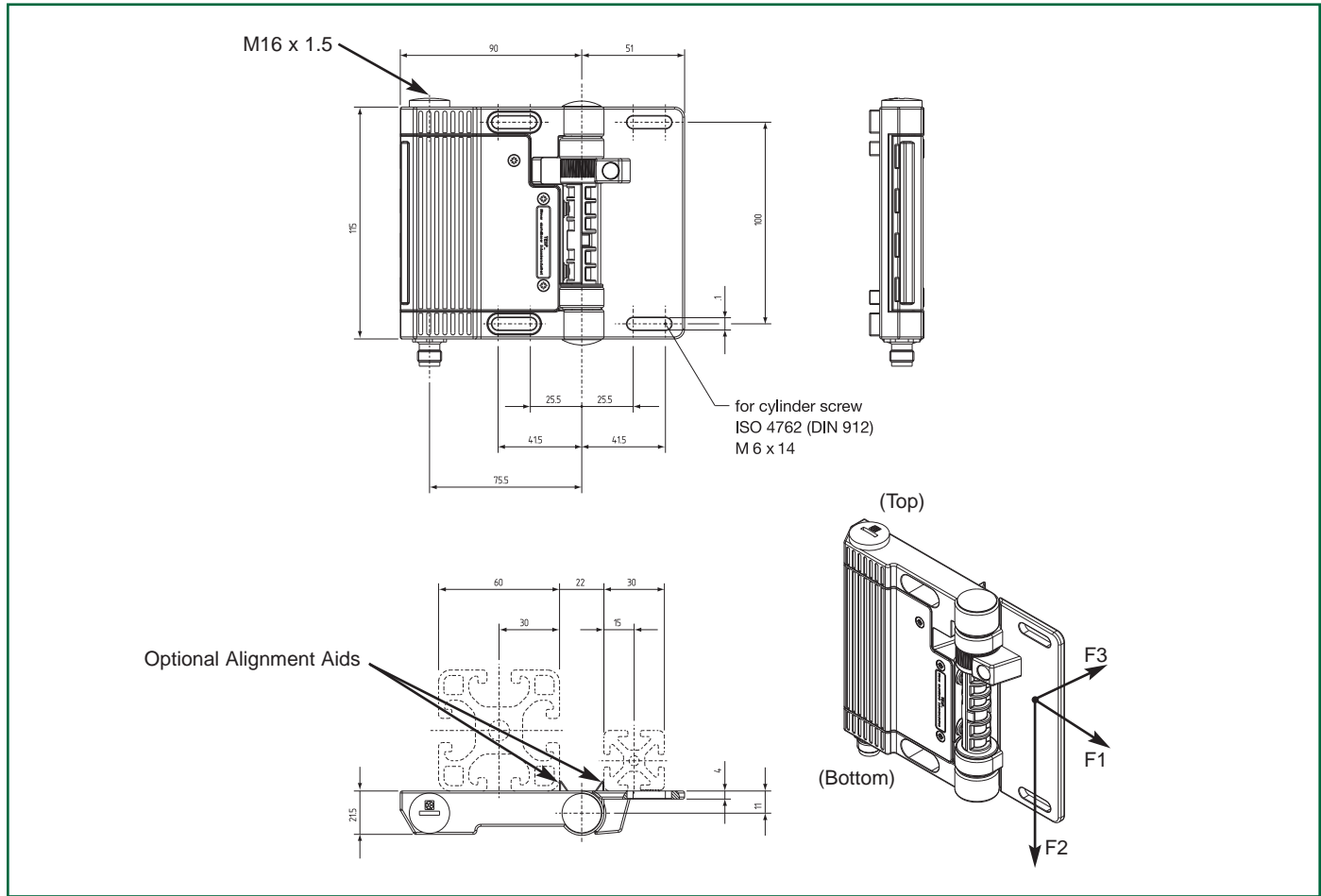

DIMENSIONS (ADDITIONAL HINGE SHOWN WITH ALIGNMENT AIDS)

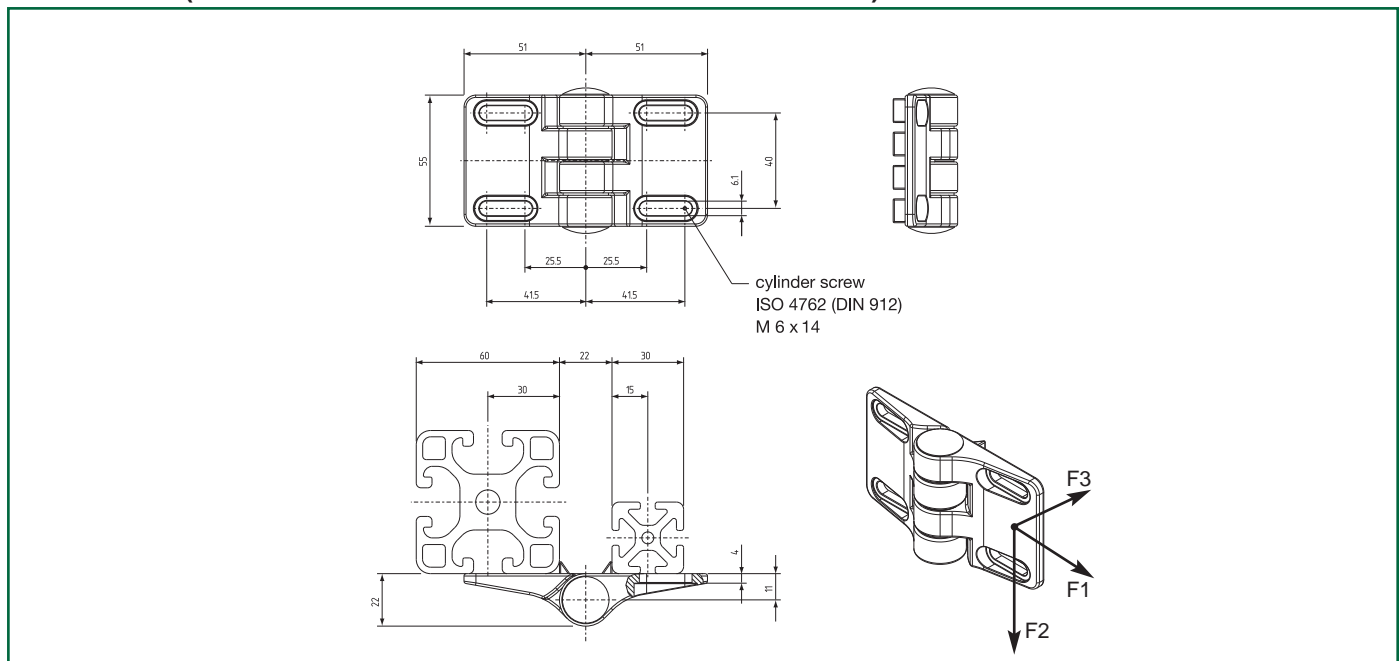

SERIES TESF TECHNICAL DATA

DETERMINING THE DOOR GAP AS DEPENDENT ON OPENING ANGLE, DOOR WIDTH AND OVERLAP

| Opening angle "β" of the door | 3° | 4° | 5° | 6° | 7° | 8° | 9° | 10° |
|-------------------------------|---|-------|-------|-------|-------|-------|-------|-------|
| Door width "C" in mm | Door gap "D" in millimeters with overlap "B" = 0 mm | | | | | | | |
| 100 | 5.2 | 7.0 | 8.7 | 10.4 | 12.2 | 13.9 | 15.6 | 17.4 |
| 150 | 7.8 | 10.5 | 13.1 | 15.7 | 18.3 | 20.9 | 23.5 | 26.0 |
| 200 | 10.5 | 13.9 | 17.4 | 20.9 | 24.4 | 27.8 | 31.3 | 34.7 |
| 250 | 13.1 | 17.4 | 21.8 | 26.1 | 30.5 | 34.8 | 39.1 | 43.3 |
| 300 | 15.7 | 20.9 | 26.1 | 31.3 | 36.5 | 41.7 | 46.9 | 52.1 |
| 350 | 18.3 | 24.4 | 30.5 | 36.6 | 42.6 | 48.7 | 54.7 | 60.7 |
| 400 | 20.9 | 27.9 | 34.8 | 41.8 | 48.7 | 55.6 | 62.5 | 69.4 |
| 450 | 23.5 | 31.4 | 39.2 | 47.0 | 54.8 | 62.6 | 70.4 | 78.1 |
| 500 | 26.2 | 34.9 | 43.6 | 52.2 | 60.9 | 69.6 | 78.2 | 86.8 |
| 550 | 28.8 | 38.3 | 47.9 | 57.5 | 67.0 | 76.5 | 86.0 | 95.5 |
| 600 | 31.4 | 41.8 | 52.3 | 62.7 | 73.1 | 83.5 | 93.8 | 104.1 |
| 650 | 34.0 | 45.3 | 56.6 | 67.9 | 79.2 | 90.4 | 101.6 | 112.8 |
| 700 | 36.6 | 48.8 | 61.0 | 73.1 | 85.3 | 97.4 | 109.4 | 121.5 |
| 750 | 39.2 | 52.3 | 65.3 | 78.4 | 91.4 | 104.3 | 117.3 | 130.2 |
| 800 | 41.8 | 55.8 | 69.7 | 83.6 | 97.4 | 111.3 | 125.1 | 138.8 |
| 850 | 44.5 | 59.3 | 74.0 | 88.8 | 103.5 | 118.2 | 132.9 | 147.5 |
| 900 | 47.1 | 62.7 | 78.4 | 94.0 | 109.6 | 125.2 | 140.7 | 156.2 |
| 950 | 49.7 | 66.2 | 82.8 | 99.3 | 115.7 | 132.1 | 148.5 | 164.9 |
| 1,000 | 52.3 | 69.7 | 87.1 | 104.5 | 121.8 | 139.1 | 156.4 | 173.6 |
| 1,050 | 54.9 | 73.2 | 91.5 | 109.7 | 127.9 | 146.1 | 164.2 | 182.2 |
| 1,100 | 57.5 | 76.7 | 95.8 | 114.9 | 134.0 | 153.0 | 172.0 | 190.9 |
| 1,150 | 60.2 | 80.2 | 100.2 | 120.1 | 140.1 | 160.0 | 179.8 | 199.6 |
| 1,200 | 62.8 | 83.7 | 104.5 | 125.4 | 146.2 | 166.9 | 187.6 | 208.3 |
| 1,250 | 65.4 | 87.2 | 108.9 | 130.6 | 152.3 | 173.9 | 195.4 | 217.0 |
| 1,300 | 68.0 | 90.6 | 113.2 | 135.8 | 158.4 | 180.8 | 203.3 | 225.6 |
| 1,350 | 70.6 | 94.1 | 117.6 | 141.0 | 164.4 | 187.8 | 211.1 | 234.3 |
| 1,400 | 73.2 | 97.6 | 122.0 | 146.3 | 170.5 | 194.7 | 218.9 | 243.0 |
| 1,450 | 75.8 | 101.1 | 126.3 | 151.5 | 176.6 | 201.7 | 226.7 | 251.7 |
| 1,500 | 78.5 | 104.6 | 130.7 | 156.7 | 182.7 | 208.7 | 234.5 | 260.3 |

Calculation example

The actual door gap "D1" is calculated from the door gap "D" calculated according to the above table less the overlap of door and frame "B":

$$D1 = D - B$$

Example: A door made of 40 mm aluminium profile with a length of 950 mm is to be secured with a TESF. According to the technical data sheet the safety contact of the TESF opens at 3° in new state (5° at end of useful life). In new state a door gap of approx. 49.7 mm is derived from the above table. The actual door gap, calculated using the above formula $D1 = D - B$ produces $(49.7 - 40 = 9.7)$; $D1 = 9.7$ mm. At the end of useful life there is a door gap of approx. 82.8 mm and an actual door gap of $(82.8 - 40 = 42.8)$; $D1 = 42.8$ mm.

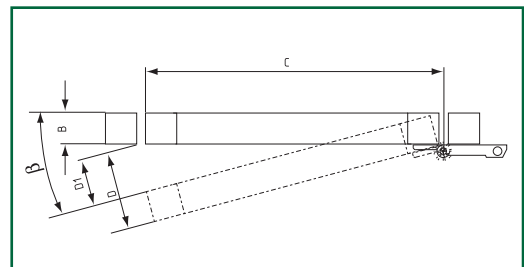



Features & Benefits

- **Tamper-resistant** ... integral switch element and actuator prevents bypassing.
- **“Positive-break” NC contacts** ... ensure circuit interruption upon only 4° of guard displacement.
- **Splashproof design** ... meets IP65 environmental requirements.
- **Rugged construction** ... tolerates mechanical abuse and hostile environments.
- **Meets rigid safety agency standards** ... IEC, BG. (UL and CSA pending)
- **Easy to install** ... fits most popular extruded hinged guard designs.
- **Compatible with popular extruded profile widths.**
- **Optional integral manual reset** ... please consult factory.

AVAILABLE STANDARD MODELS

| Part Number* | Contacts (Guard Closed) | Description |
|----------------------------|-------------------------|---|
| TESZ1102/30 TESZ1110/30 | 1 NO & 2 NC 3 NC | Hinged safety interlock switch for 30mm width extruded guards |
| TESZ1102/35 TESZ1110/35 | 1 NO & 2 NC 3 NC | Hinged safety interlock switch for 35mm width extruded guards |
| TESZ1102** TESZ1110** | 1 NO & 2 NC 3 NC | Hinged safety interlock switch for 40mm width extruded guards |
| TESZ1102/45 TESZ1110/45 | 1 NO & 2 NC 3 NC | Hinged safety interlock switch for 45mm width extruded guards |

*Includes hinge assembly with switch, switch actuator and an additional hinge assembly (without switch or switch actuator).

**Available with stainless-steel hinges. (Please consult factory)

Description

The TESZ Series are designed for use with hinged movable machine guards which must be closed for operator safety. Their tamper-resistant design and positive-opening NC contacts provide a significantly higher level of safety than conventional, spring-driven limit switches often used to monitor hinged-guard position. Their compact, low-profile design and IP65 rating make them ideal for interlocking hinged safety guards in industrial environments. Designed to mount directly on the hinged guard and its stationary frame, it is easy to install on a wide range of guard styles and sizes.

Operation



The installed TESZ features an integral electromechanical switch element which is actuated when opening a hinged machine guard. After opening the guard only 4°, the unit's positive-break, normally-closed contact(s) are forced to open by a direct (non-resilient) actuating mechanism. These positive-break contacts ensure circuit interruption and machine stoppage. The normally-open signalling contact closes after 13.5° of guard displacement.

Note: Adjustable switching point series TESF hinge model available. Suitable for front of guard or inside mounting. See page 210.

AVAILABLE ACCESSORIES

| Part Number* | Description |
|--------------|---|
| TESZ/S/30 | Hinge assembly (without switch or switch actuator) for 30mm width extruded guards |
| TESZ/S/35 | Hinge assembly (without switch or switch actuator) for 35mm width extruded guards |
| TESZ/S | Hinge assembly (without switch or switch actuator) for 40mm width extruded guards |
| TESZ/S/45 | Hinge assembly (without switch or switch actuator) for 45mm width extruded guards |

*Includes hinge and hinge pin.

SWITCHING DIAGRAMS & CONTACT SCHEMATICS

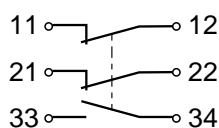

TESZ1102

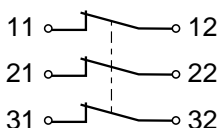
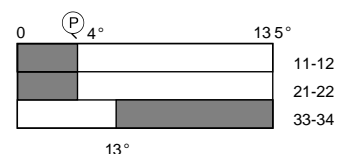

TESZ1110

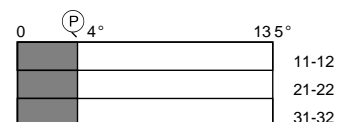

SERIES TESZ TECHNICAL DATA

MECHANICAL SPECIFICATIONS

| | |
|--|--|
| Materials of Construction | Hinge: Aluminum Switch Cover: Thermoplastic |
| Displacement Angle for NC Contact Opening | 4° |
| Degree of Protection | IP65 |
| Displacement Angle for NO Contact Closing | 13.5° |
| Maximum Opening Angle | 135° |
| Operating Temperature | -13°F to +149°F |
| Mechanical Life | >10 ⁶ operations |
| Mechanical Loading Capacity | Maximum torque of 3KN/m at 1m distance from hinge |
| Operating Rate | 1,200 operations/hour (maximum) |
| Shock Tolerance | 30g/18ms |
| Vibration Tolerance | 20g/10... 200Hz |
| Conformity to Standards | IEC 947-5-1 EN60947-5-1 DIN VDE 0660 EN 1088 UL CSA |

ELECTRICAL SPECIFICATIONS

| | |
|--|---|
| Contacts | Fine silver |
| Contact Configuration | Double-pole, double-break with electrically-separated contact bridges |
| Contact Rating | 2A (250VAC), AC-15, DC-13 |
| Switching Action | Slow-acting, positive-break NC contact |
| Short Circuit Protection | 6.0A (Slow blow) |
| Rated Insulation Voltage | 250VAC (maximum) |
| Rated Impulse Withstand Voltage | 2.5kV |
| Electrical Connections | Screw terminals for 15 AWG maximum stranded wire size |

DIMENSIONS

TESZ1102 & TESZ1110 SERIES

| Part Number | Dimension "A" | Dimension "B" | Dimension "C" |
|----------------------------|---------------|---------------|---------------|
| TESZ1102/30 TESZ1110/30 | 1.34" (34mm) | 5.28" (132mm) | 4.41" (112mm) |
| TESZ1102/35 TESZ1110/35 | 1.53" (39mm) | 5.28" (132mm) | 4.41" (112mm) |
| TESZ1102 TESZ1110 | 1.73" (44mm) | 3.62" (92mm) | 2.44" (62mm) |
| TESZ1102/45 TESZ1110/45 | 1.93" (49mm) | 5.28" (132mm) | 4.41" (112mm) |

TESZ/S SERIES



Typical Applications

The ES95 SB is intended for use as a safety interlock switch on hinged, movable machine guards which, when open, expose operator/maintenance personnel to machine hazards. Their sealed design (IP67) and oil-tolerant seals make them ideal for use in hostile environments.

Features & Benefits

- **Tamper-resistant** ... integral actuator shaft prevents bypassing.
- **“Positive-break” NC contacts** ... ensure circuit interruption upon only 7° of guard displacement.
- **Watertight, oiltight design** ... meets IP67 washdown and immersion requirements.
- **Rugged, corrosion-resistant housing** ... tolerates the most hostile environments.
- **Meets rigid safety agency standards** ... CSA, IEC and BG.
- **Four 90° actuator head positions** ... provide installation flexibility.

Description

The ES95 SB Series are designed for use with hinged movable machine guards which must be closed for operator safety. Their tamper-resistant design and positive-opening NC contacts provide a significantly higher level of safety than conventional, spring-driven limit switches often used to monitor hinged-guard position. Their IP67 rating make them ideal for interlocking safety guards in hostile environments.

AVAILABLE STANDARD MODELS

| Part Number | Contacts (Guard Closed) | Description* |
|--------------|-------------------------|---|
| ES95-SB10/1S | 1 NO & 1 NC | Hinged safety interlock switch with 10mm diameter shaft bore hole |
| ES95-SB20 | 2 NC | |

*The actuator head may be rotated into any one of four 90° positions.

Operation



The ES95 SB is a single-piece, electromechanical safety interlock switch which is designed to mount to a hinged machine guard. After opening the guard only 7°, the unit's positive-break, normally-closed contacts are forced to open by a direct (non-resilient) actuating mechanism. These positive-break stop contacts ensure circuit interruption (and machine stoppage).

Shown with Safety-Rated Positive-Break® limit switch.

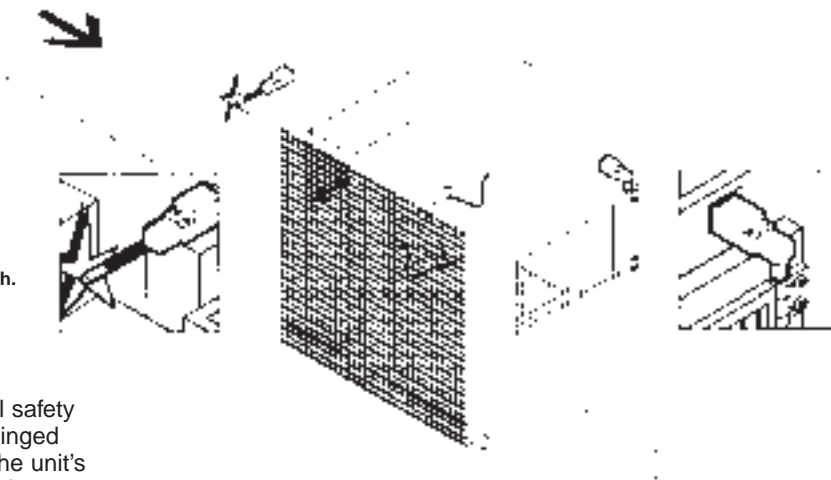

ES95 SB TECHNICAL DATA

MECHANICAL SPECIFICATIONS

| | |
|---|--|
| Housing | Glass-fibre reinforced, self-extinguishing thermoplastic |
| Displacement Angle for Contact Opening | 7° |
| Degree of Protection | IP67 |
| Operating Temperature | -22°F to +195°F |
| Mechanical Life | 10 million operations |
| Operating Rate | 3,600 operations/hour (maximum) |
| Mounting Arrangement | Mounts on 9mm diameter shaft via mounting screw |
| Conformity to Standards | BG CSA SUVA |

ELECTRICAL SPECIFICATIONS

| | |
|--|---|
| Contacts | Fine silver |
| Contact Configuration | Double-pole, double-break with electrically-separated contact bridges |
| Contact Rating | 5A/24VAC 6A/400VAC |
| Switching Action | Slow-action, positive-break NC contacts |
| Rated Insulation Voltage | 500VAC |
| Rated Impulse Withstand Voltage | 6kV |
| Type Terminals | Screw terminals with self-lifting clamps for up to 13AWG |

SWITCHING DIAGRAM

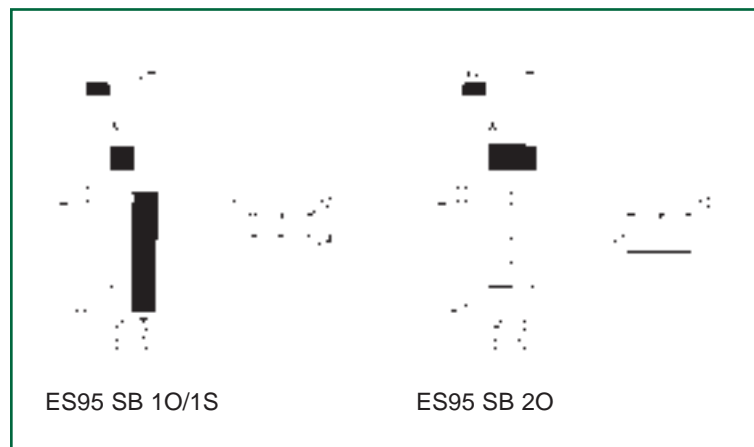

DIMENSIONS

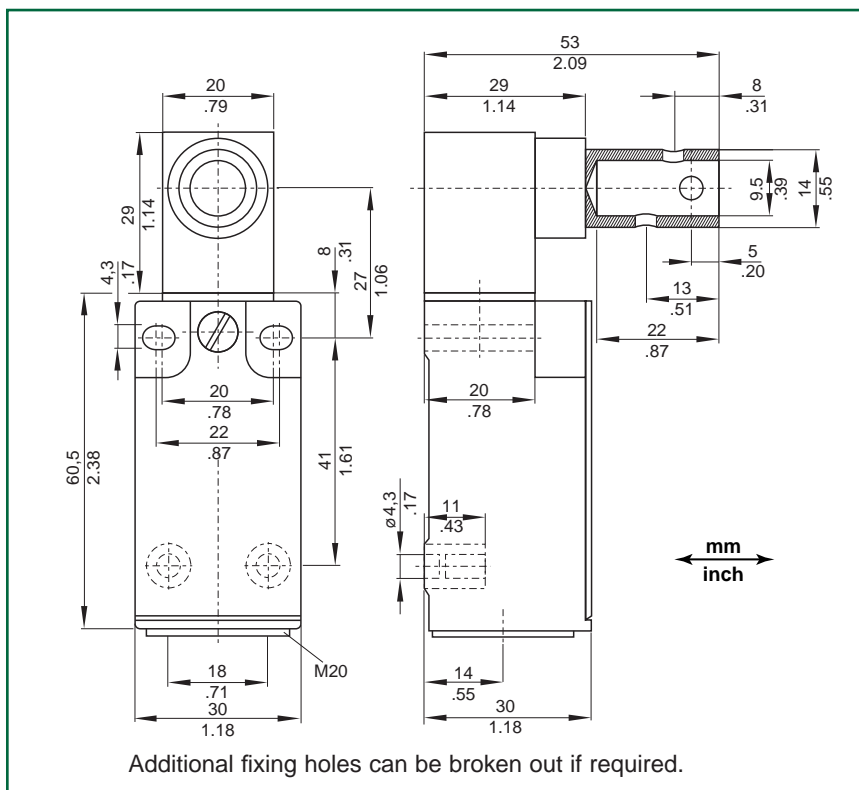

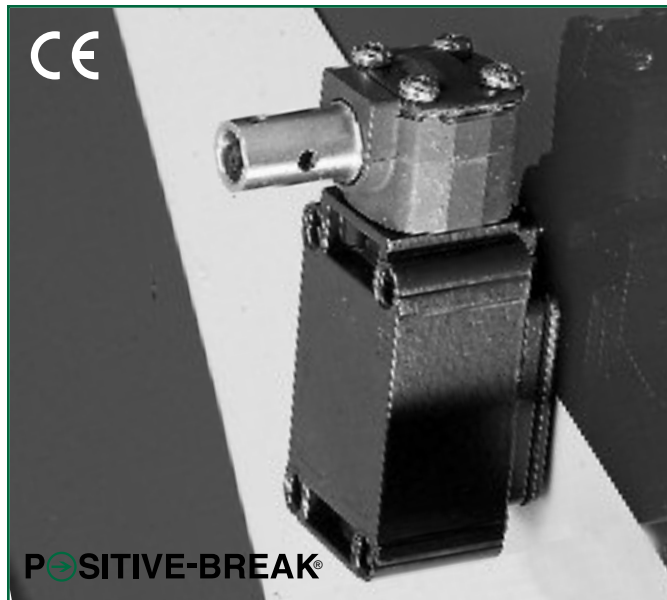

Features & Benefits

- **Tamper-resistant** ... integral actuation shaft prevents bypassing.
- **“Positive-break” NC contacts** ... ensure circuit interruption upon only 3° of guard displacement.
- **Watertight design** ... meets IP67 washdown and immersion requirements.
- **Rugged, corrosion-resistant housing** ... tolerates the most hostile environments.
- **Meets rigid safety agency standards** ... IEC, BG, UL and CSA.
- **Four 90° actuator head positions** ... provide installation flexibility.
- **Optional LED indicators** ... provide visual display of supply voltage and switch operation.

Description

The TVS335 Series are designed for use with hinged movable machine guards which must be closed for operator safety. Their tamper-resistant design and positive-opening NC contacts provide a significantly higher level of safety than conventional, spring-driven limit switches often used to monitor hinged-guard position. Their IP67 rating make them ideal for interlocking safety guards in hostile environments.

Operation



The TVS335 is a single-piece, electromechanical safety interlock switch which is designed to mount to a hinged machine guard. After opening the guard only 3°, the unit's positive-break, normally-closed contacts are forced to open by a direct (non-resilient) actuating mechanism. These positive-break contacts ensure circuit interruption (and machine stoppage).

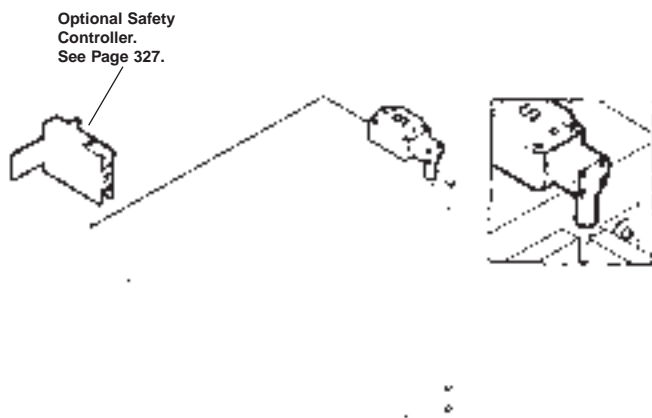

AVAILABLE STANDARD MODELS

| Part Number | Contacts (Guard Closed) | Description* |
|------------------|-------------------------|--|
| TV8S-335-11Z | 1 NO & 1 NC | Hinged safety interlock switch with 8mm diameter shaft bore hole |
| TV8S-335-02Z | 2 NC | |
| TV10S-335-11Z | 1 NO & 1 NC | Hinged safety interlock switch with 10mm diameter shaft bore hole |
| TV10S-335-02Z | 2 NC | |
| TV8S-335-11ZG24 | 1 NO & 1 NC | Hinged safety interlock switch with 8 mm diameter shaft bore and integral LED indicators for supply voltage (green) and switch operation (yellow) |
| TV8S-335-02ZG24 | 2 NC | |
| TV10S-335-11ZG24 | 1 NO & 1 NC | Hinged safety interlock switch with 10 mm diameter shaft bore and integral LED indicators for supply voltage (green) and switch operation (yellow) |
| TV10S-335-02ZG24 | 2 NC | |

*The actuator head may be rotated into any one of four 90° positions.

TVS335 TECHNICAL DATA

MECHANICAL SPECIFICATIONS

| | |
|--|--|
| Housing | Diecast aluminum, enamel finish |
| Displacement Angle for Contact Opening | 3° |
| Degree of Protection | IP67 |
| Operating Temperature | -22°F to +158°F |
| Mechanical Life | >10 ⁶ operations |
| Operating Rate | 5,000 operations/hour (maximum) |
| Conformity to Standards | IEC 947-5-1 EN 60947-5-1 DIN VDE 0660-200 BG-GS-ET15 UL CSA |

ELECTRICAL SPECIFICATIONS

| | |
|---------------------------------|--|
| Contacts | Fine silver |
| Contact Configuration | Double-pole, double-break with electrically-separated contact bridges |
| Contact Rating | 4A (230VAC) 2.5A (400VDC) 1A (500VAC) |
| Switching Action | Slow-action, positive-break NC contacts |
| Short Circuit Protection | Fuse 6A (time-delay) |
| Rated Insulation Voltage | 500VAC |
| Rated Impulse Withstand Voltage | 6kV |
| Electrical Connections | Screw terminals with self-lifting clamps 13AWG (2.5mm ²) maximum wire size |

DIMENSIONS

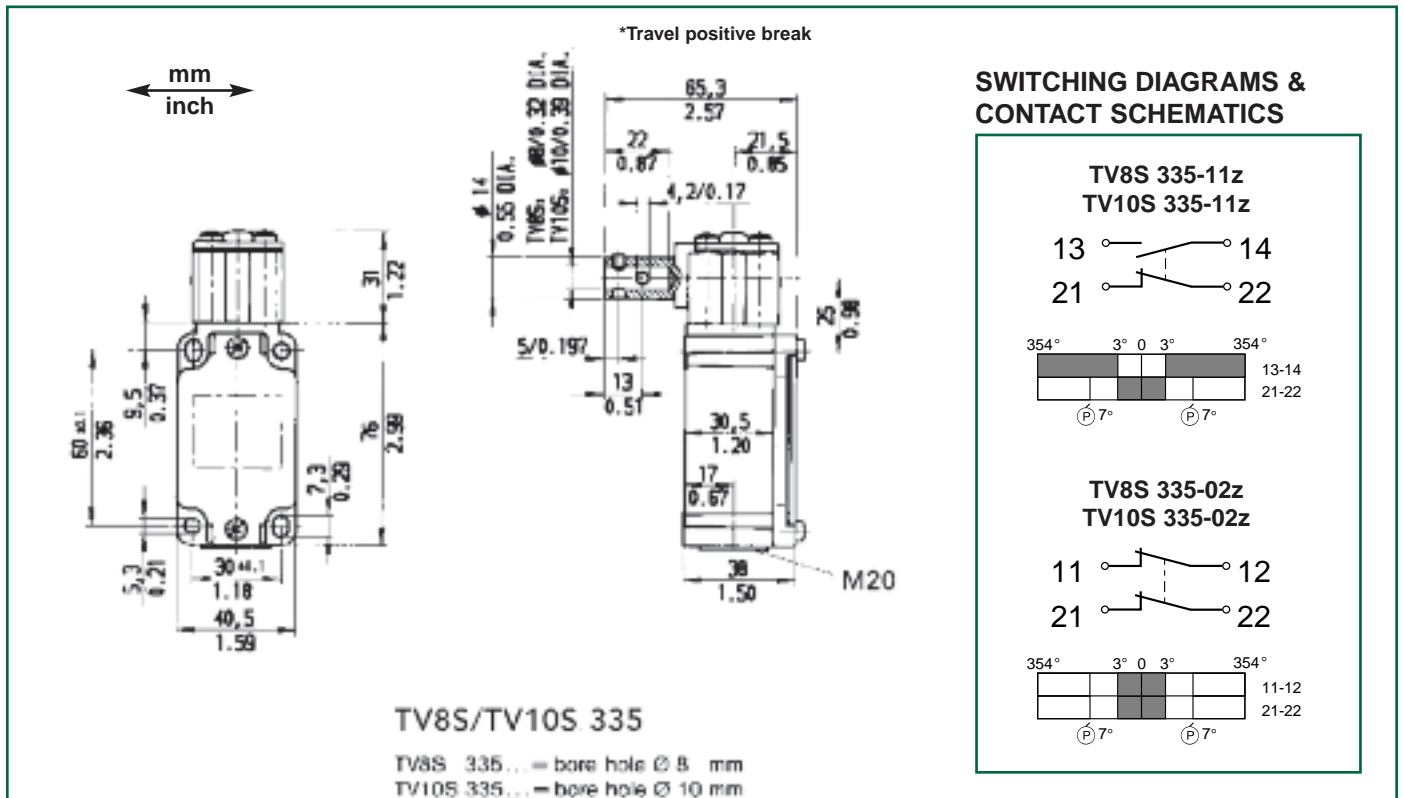

SWITCHING DIAGRAMS & CONTACT SCHEMATICS

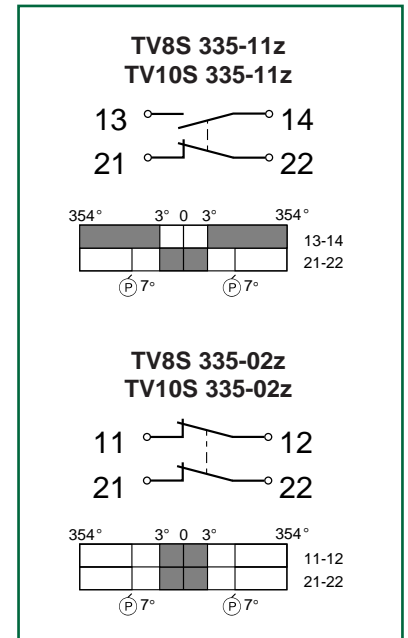

LED Indicators

Green LED (gn) indicator for supply voltage and yellow LED (ge) indicator for switch operation for 24VDC. The LED's must not be wired, however, in the safety circuit!

Shown here:
TV8S 335-11zG24

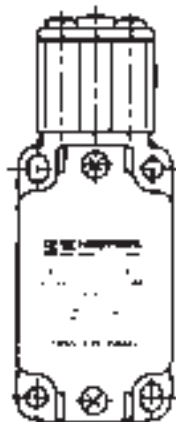

Shown here:
NO contact (model -11zG24) serves for alarm and signaling purposes.

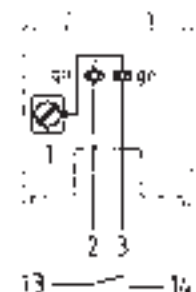
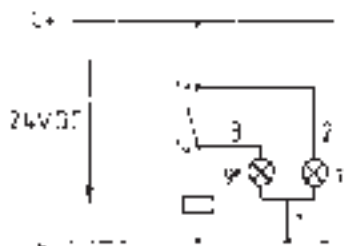

Protected against wrong polarity connection.
Protected against transient voltages.



Features & Benefits

- **Tamper-resistant** ... integral actuator arm prevents bypassing by operator.
- **“Positive-break” NC contacts** ... ensure circuit interruption upon only 4.5° of guard displacement.
- **Watertight design** ... meets IP67 washdown and immersion requirements.
- **Rugged, corrosion-resistant housing** ... tolerates the most hostile environments.
- **Meets rigid safety agency standards** ... IEC, BG, UL and CSA.
- **Four 90° actuator head positions** ... provide installation flexibility.

Description

The T.C 235/236 Series are designed for use with hinged movable machine guards which must be closed for operator safety. Their tamper-resistant design and positive-opening NC contacts provide a significantly higher level of safety than conventional, spring-driven limit switches often used to monitor hinged-guard position. Their IP67 rating make them ideal for interlocking safety guards in hostile environments.

Operation

The T.C 235/236 is a single-piece, electromechanical safety interlock switch which is designed to mount to a hinged machine guard. After opening the guard only 4.5°, the unit's positive-break, normally-closed contacts are forced to open by a direct (non-resilient) actuating mechanism. These positive-break contacts ensure circuit interruption (and machine stoppage).

Typical Applications



The T.C 235/236 is intended for use as a safety interlock switch on hinged, movable machine guards which, when open, expose operator/maintenance personnel to machine hazards. Their sealed design (IP67) and oil-tolerant seals make them ideal for use in hostile environments.

AVAILABLE STANDARD MODELS

| Part Number | Contacts (Guard Closed) | Description* |
|--------------------------|-------------------------|--|
| T3C235-11Z T3C236-11Z | 1 NO & 1 NC | Hinged safety interlock switch with actuating lever to right in rest position |
| T3C235-02Z T3C236-02Z | 2 NC | |
| T3C235-01Z T3C236-01Z | 1 NC | |
| T4C235-11Z T4C236-11Z | 1 NO & 1 NC | Hinged safety interlock switch with actuating lever vertical to switch body in rest position |
| T4C235-02Z T4C236-02Z | 2 NC | |
| T4C235-01Z T4C236-01Z | 1 NC | |
| T5C235-11Z T5C236-11Z | 1 NO & 1 NC | Hinged safety interlock switch with actuating lever to left in rest position |
| T5C235-02Z T5C236-02Z | 2 NC | |
| T5C235-01Z T5C236-01Z | 1 NC | |

*The actuator head may be rotated into any one of four 90° positions.

T.C 235/236 TECHNICAL DATA

MECHANICAL SPECIFICATIONS

| | |
|---|--|
| Housing | (Series 235): Diecast zinc, enamel finish (Series 236): Glass-fiber, reinforced, self-extinguishing thermoplastic |
| Displacement Angle for Contact Opening | 4.5° |
| Degree of Protection | IP67 |
| Operating Temperature | -22°F to +175°F |
| Mechanical Life | >106 operations |
| Operating Rate | 5,000 operations/hour (maximum) |
| Conformity to Standards | IEC 947-5-1 EN 60947-5-1 DIN VDE 0660-200 BG-GS-ET15 DIN-EN50047 UL CSA |

ELECTRICAL SPECIFICATIONS

| | |
|--|--|
| Contacts | Fine silver |
| Contact Configuration | Double-pole, double-break with electrically-separated contact bridges |
| Contact Rating | 4A (230VAC) 2.5A (400VDC) 1A (500VAC) |
| Switching Action | Slow-action, positive-break NC contacts |
| Short Circuit Protection | Fuse 6A (time-delay) as a positive-break switch |
| Rated Insulation Voltage | 500VAC |
| Rated Impulse Withstand Voltage | 6kV |
| Electrical Connections | Screw terminals with self-lifting clamps for 13AWG (2.5mm ²) maximum wire size |

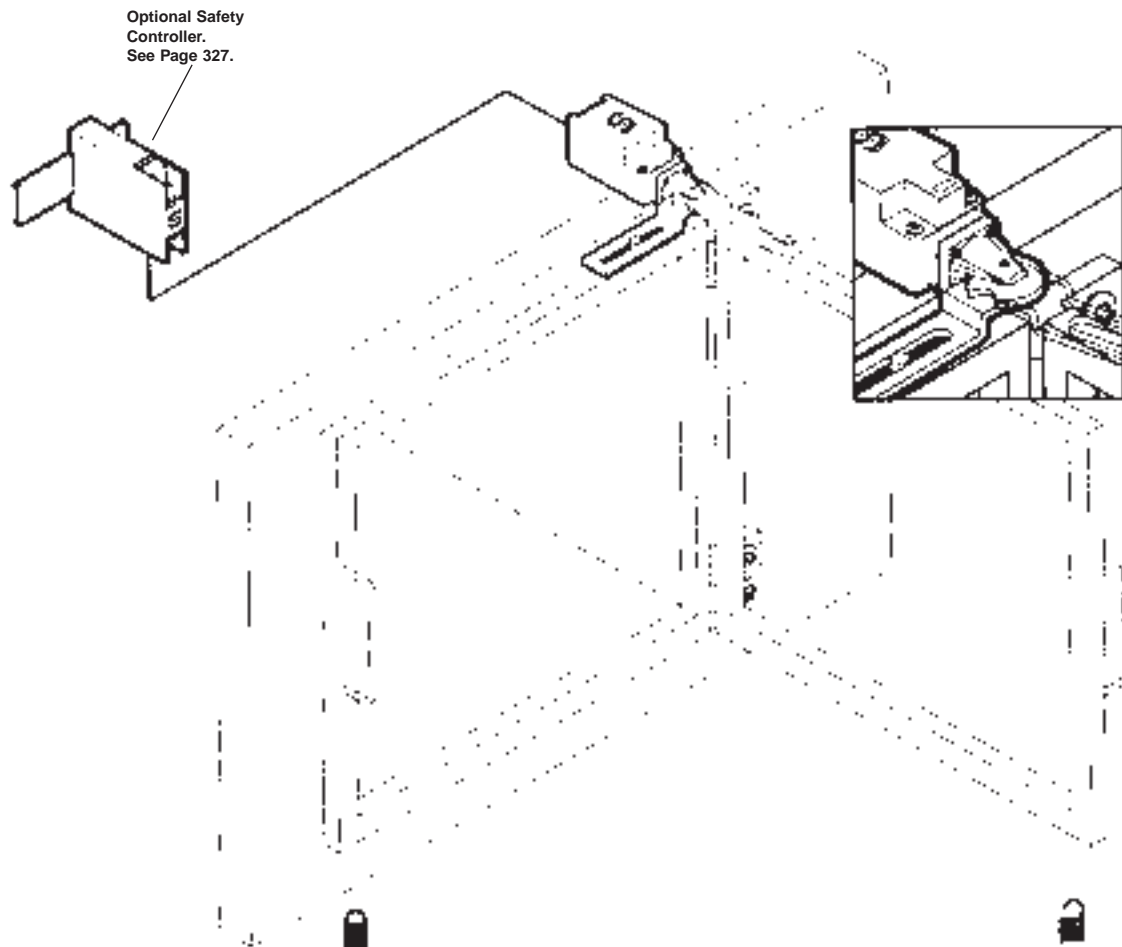

T.C 235 TECHNICAL DATA

Contact function diagrams

Slow action
1 NO + 1 NC

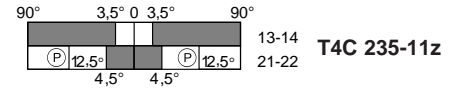
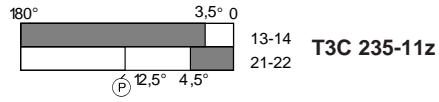

Slow action
2 NC

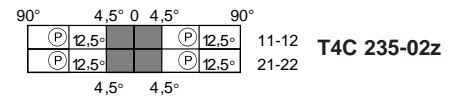
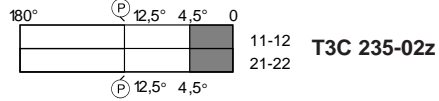

Slow action
1 NC

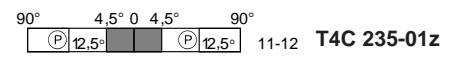
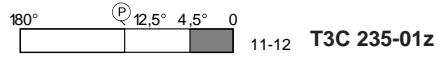

Dimensions

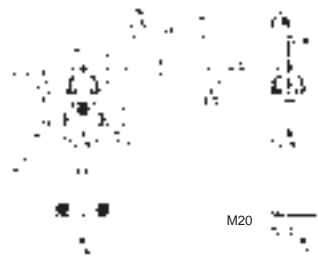
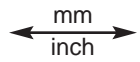

Types of Actuator Levers

Lever 3 C

Lever 4 C

| Part No. | Diagram | Action | Part No. | Part No. |
|----------|---------|-------------|--------------------|--------------------|
| | | Slow action | T3C 235-11z | T4C 235-11z |
| | | Slow action | T3C 235-02z | T4C 235-02z |
| | | Slow action | T3C 235-01z | T4C 235-01z |

T.C 235 TECHNICAL DATA

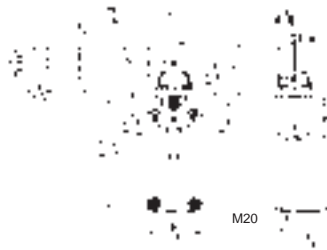
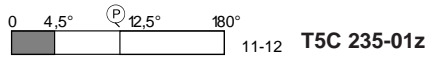
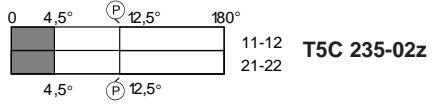
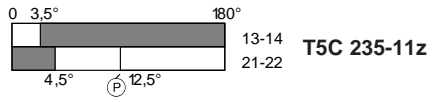

Lever 5 C

T5C 235-11z

T5C 235-02z

T5C 235-01z

T.C 236 TECHNICAL DATA

Contact function diagrams

Slow action
1 NO + 1 NC

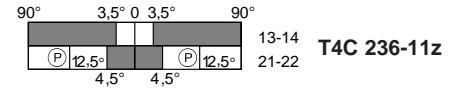
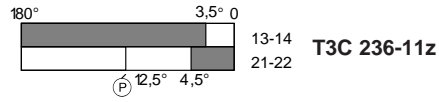

Slow action
2 NC

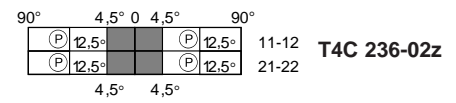
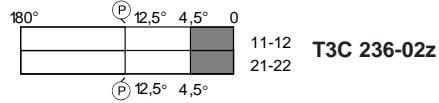

Slow action
1 NC

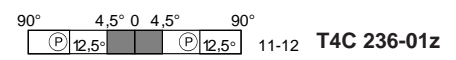
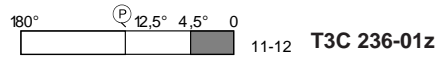

Dimensions

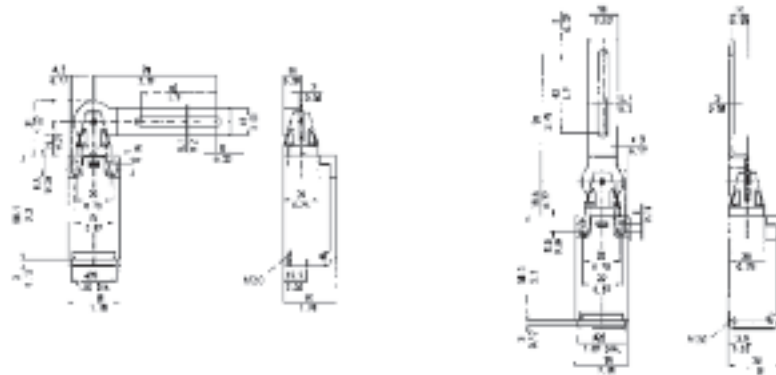
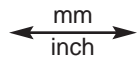

Types of Actuator Levers

Lever 3 C

Lever 4 C

| | | | | |
|----------|----------------|-------------|-------------|-------------|
| Part No. | 13-14 21-22 | Slow action | T3C 236-11z | T4C 236-11z |
| | 11-12 21-22 | Slow action | T3C 236-02z | T4C 236-02z |
| | 11-12 | Slow action | T3C 236-01z | T4C 236-01z |

T.C 236 TECHNICAL DATA

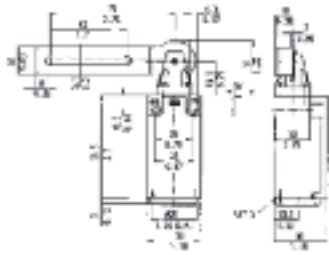
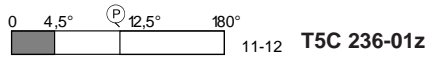
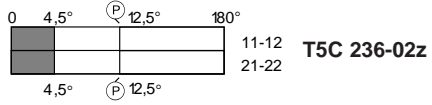
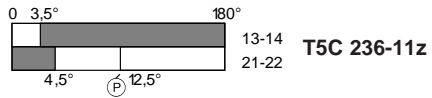

Lever 5 C

T5C 236-02z