

# FAIL-TO-SAFE SAFETY EDGES

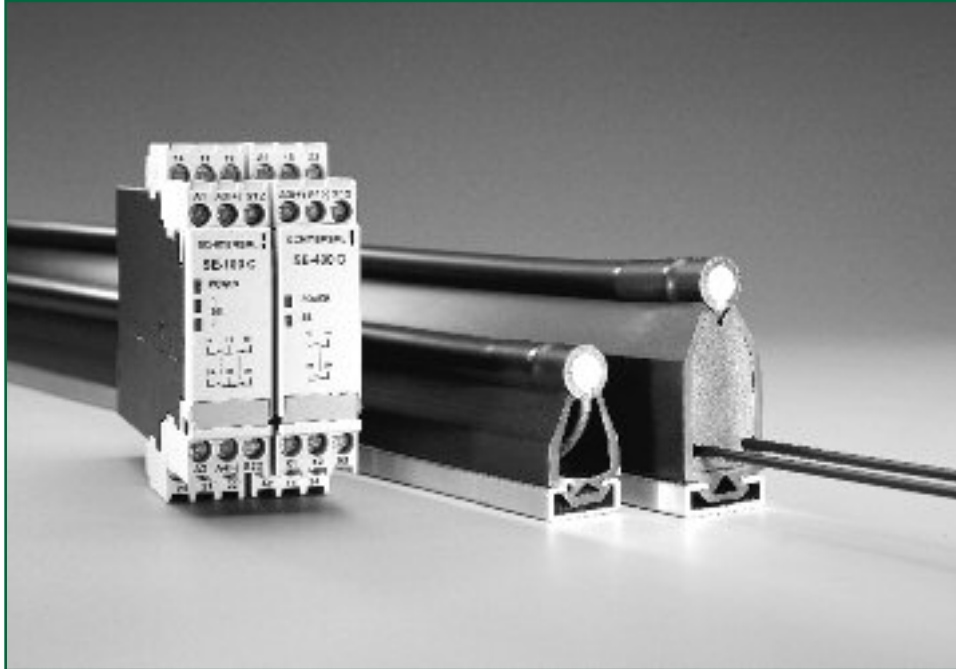

## SELECTION GUIDE

SCHMERSAL's Series SE Safety Edges/Bumpers are available as sub-assembly components or as custom assemblies produced to user specifications. The following pages provide details regarding operation, construction and ordering details. Among the user options are safety edge profile, mounting frame profile and length. Please contact us if you have any questions, special needs or require assistance with properly specifying the safety edge which meets your requirements.

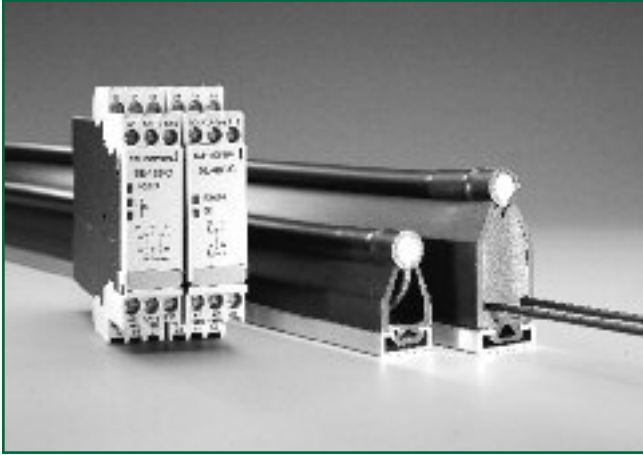

### Description

The series SE Safety edge consists of a rugged high tear resistant rubber profile, an aluminum mounting rail, a plug-in optoelectronic transmitter and receiver pair and a compatible safety controller. The design features a high reflective internal rubber surface and a self-adjusting gain optical pair whose performance is uncompromised by slight bending ... and predictable over the specified operating range.

Units can be quickly and easily assembled (without special skills or use of adhesives) for lengths of 400 mm to 10 m.

The self adjusting optical pair assure the same sensitivity and performance independent of chosen length.

The mechanical design assures encapsulation of the transmitter and receiver ensuring reliable operation unaffected by environmental soiling.

### Operation

In operation the transmitted IR beam is detected, by the receiver resulting in enabling of the safety controllers safety output(s). Deformation of the rubber profile interrupts/weakens the signal between the transmitter and receiver. This is sensed by the safety controller disabling the outputs allowing the hazardous movement to be stopped. Depending upon the choice of safety controller the system meets the requirements of EN 954-1 Safety control category 1 or 4.

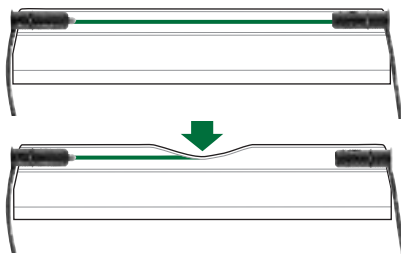

### Features & Benefits

- **Can be cut & mounted in the field** ... easy to fit and adjust length when placing the edge on the door
- **Safety controller SE 100 handles up to 2 safety edges** ... reduced cost in multiple door applications
- **Rugged corrosion & abrasion resistance rubber profiles** ... tolerant to most industrial environments
- **Watertight design** ... meets IP 68 environmental requirements.
- **Low operating force** ... assures reliable operation
- **Automatic gain control** ... tolerates slight bending
- **Simple field installation** ... low cost & easy to repair
- **Meets rigid safety agency standards** ... BG, UL and CSA

### Typical Applications

Ideal wherever crushing or shearing points are to be safeguarded, such as on guard doors, elevating platforms, rising stages, moving stock shelving, operating process tables, loading ramps, hoists or tipping equipment.

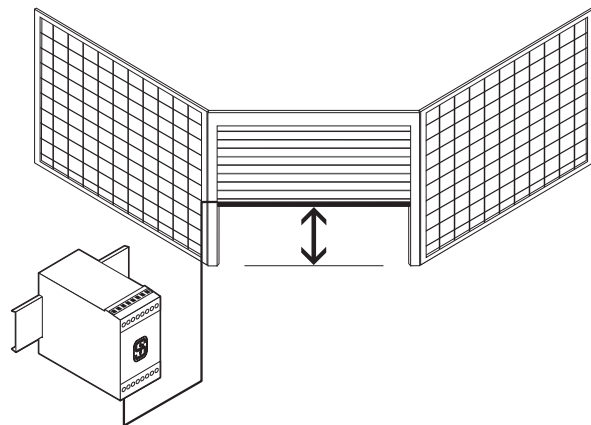

Note: Not recommended for use on overhead doors. Please consult factory for such applications.

# SERIES SE ORDERING & ASSEMBLY INFORMATION

## AVAILABLE SUBASSEMBLY COMPONENTS

Parts required for a system are:

Aluminum profile, rubber profile,  
sensor set and safety controller

Aluminum Profile	Description
SE-AL10-1250	1.25 m
SE-AL10-2500	2.50 m
SE-AL12-1250	1.25 m
SE-AL12-2500	2.50 m
SE-AL20-1250	1.25 m
SE-AL20-2500	2.50 m
SE-AL22-1250	1.25 m
SE-AL22-2500	2.50 m
Rubber Profile	Description
SE- P 40 - 1250 mm	SE-P40 - 1250
SE- P 40 - 2500 mm	SE-P40 - 2500
SE- P 70 - 1250 mm	SE-P70 - 1250
SE- P 70 - 2500 mm	SE-P70 - 2500
Sensor Set	Description
SE- SET	SE - T Transmitter & SE - R Receiver
Safety Controller	Description
SE- 100C (2 Bumpers)	Safety Control Category 1
SE- 400C	Safety Control Category 4
SE- 304C (4 Bumpers)	Safety Control Category 3 (Please contact factory for details)
Accessories	Description
SE- EC 40 (2 required)	End Cap for SE - P 40
SE- EC 70 (2 required)	End Cap for SE - P 70
SE- SC	Rubber profile shears
SE- WA	Wiring aid
SE- J1	Junction Box



AL 10 & AL 12 for use with P40 rubber profile.



AL 20 & AL 22 for use with P70 rubber profile



P40 Rubber profile for use with AL 10 & AL 12 mounting rail.



P70 Rubber profile for use with AL 20 & AL 22 mounting rail.

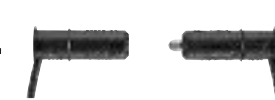

## Six steps to install the safety edge

**1** Cut aluminum rail to desired length and fasten in place



**4** Press the transmitter and receiver units into the ends of the rubber profile



**2** Cut the rubber profile to desired length



**5** Thread emitter or receiver cable through profile to desired cable exit end of rubber profile.

**3** Clip the rubber profile into the aluminum rail



**6** Connect to the desired safety controller  
It is ready !

8

# SERIES SE TECHNICAL DATA

## Aluminum Mounting Rail Profiles & Dimensions (mm)

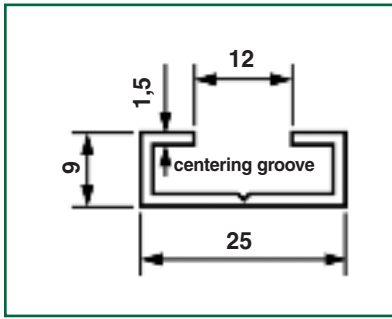

SE AL 10

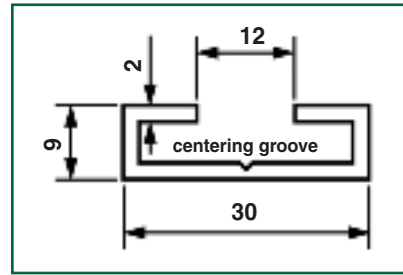

SE AL 20

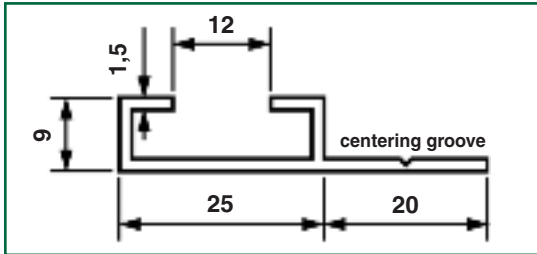

SE AL 12

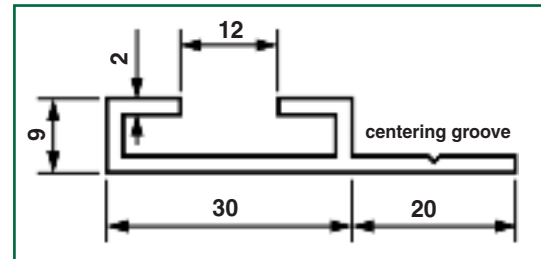

SE AL 22

## Rubber Mounting Rail Profiles & Dimensions (mm)

Table of Properties

Rubber Profile	SE - P 40 , SE - P 70
Rubber Material	EPDM , shore hardness 60
Temperature Range	- 40 °C to + 170 °C ( short term) - 30 °C to + 170 °C ( long term)
Resistance	good against ozone , moderate against oils, acids, solvents, fuels

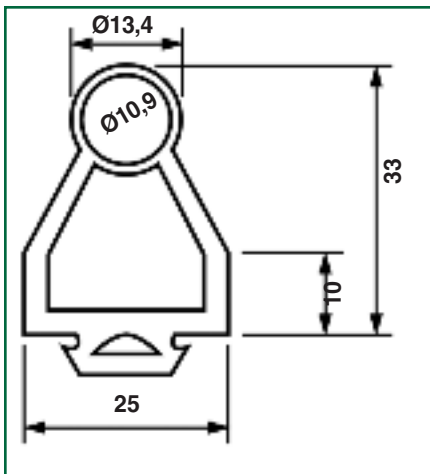

SE P 40

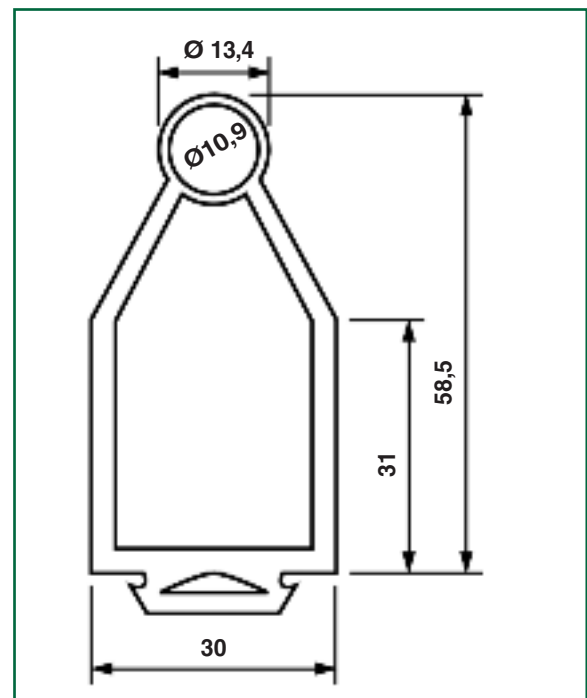

SE P 70

# SERIES SE TECHNICAL DATA

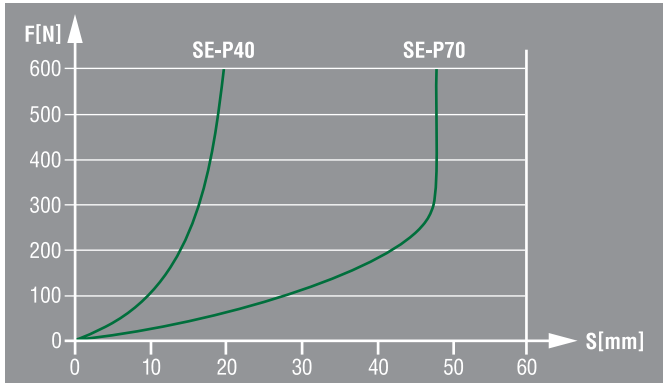

Force/Travel diagram for the rubber profiles with SE 100 C controller unit

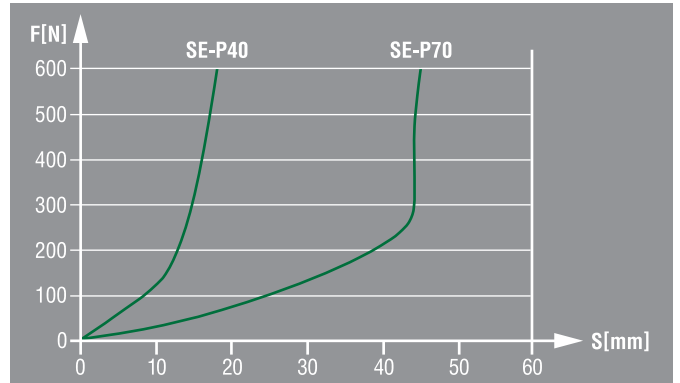

Force/Travel diagram for the rubber profiles with SE 400 C controller unit

## Force/Travel table of rubber profiles with SE-100 C

Force/Travel	Fa [N]	Sa [mm]	Fn [N]	Sn [mm]
Testing Speed	100 mm/s		10 mm/s	
SE-P40	92	9	250	16
			400	18
			600	20
SE-P70	22	8	250	46
			400	47
			600	48

## Force/Travel table of rubber profiles with SE-400 C

Force/Travel	Fa [N]	Sa [mm]	Fn [N]	Sn [mm]
Testing Speed	100 mm/s		10 mm/s	
SE-P40	140	11	250	14
			400	16
			600	18
SE-P70	23	9	250	43
			400	44
			600	45

Legend	Fa	Actuating force
	Sa	Actuating travel
	Fn	Overtravel force
	Sn	Overtravel
	Sg	Total deformation travel

$$Sg = Sa + Sn$$

The complete system is suitable for finger recognition in accordance

with the above test data.

The measurements are carried out according to EN 1760-2\*

## Test conditions

### Measurement parameters

Temperature:	T = 20 °C
Mounting position	B (to EN 1760-2*)
Place of measurement	C 3 (to EN 1760-2*)

\* preliminary

# SERIES SE TECHNICAL DATA

## Transmitter and Receiver Pair

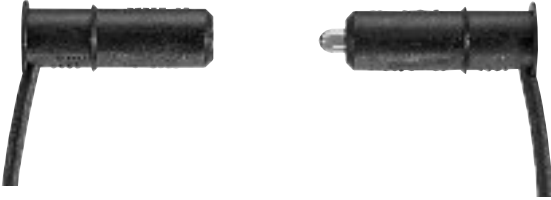

### Fitting the rubber profile in a light bend

Light bends in the profile reduce the maximum possible length of safety edge.

The infrared signal between the transmitter and receiver overcomes light bends by reflection in the inner wall of the profile and self adjusting gain to increase transmission power.

Large radii offer less resistance in this case than smaller ones.

The reflective properties of the individual batches supplied are not absolutely constant and affect the reproducibility within certain limits.

The reflective characteristics of the SE-P40 and SE-P70 profiles are the same. The SE-P40 profile allows tighter radii to be used than the SE-P70 because of its smaller dimensions. When formed into tight bends, rubber profiles tend to buckle, thus leading to total blockage of the light channel.

### Technical Data for SE - T / SE - R

Technical Data	SE - T , SE - R
Material	Polyurethane
Protection class	IP 68
Dimensions	11.5 mm dia., 37 mm long
Connecting cable	3 x 0.14 mm <sup>2</sup> stranded wire
Cable length	Transmitter 6.6 m Receiver 3 m
Permissible cable length	Max. 200 m
Operating temperature	-25 °C to +75 °C

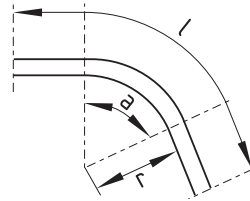

Maximum Radius (r)	Bend Angle (a)	Bend Length (l)
0 m	0°	10,0 m
1 m	15°	4,5 m
0,5 m	63°	2,5 m
0,3 m	90°	1,25 m

**Note:** Maximum edge length is a function of both bend angle and bend radius. The above values are guidelines only.

# SERIES SE TECHNICAL DATA

## SE Series Safety Controllers

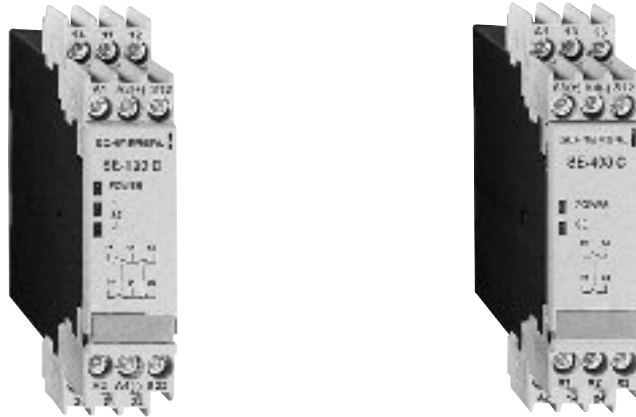

Electrical Specification	SE - 100 C	SE - 400 C
Standards	EN 1760-2, EN60947-5-1, VDE 0660 Part 200	EN1760-2, EN60947-5-1, VDE 0660 Part 200
Safety Control Category	1 to EN 954-1	4 to EN 954-1
Enclosure	PE (black), Crastin (grey)	PE (black), Crastin (grey)
Fixing	DIN rail EN 50 022	DIN rail EN 50 022
Screw terminals	max. 2 x 2.5 mm <sup>2</sup> solid wire max. 2 x 1.5 mm <sup>2</sup> stranded wire with end thimble	max. 2 x 2.5 mm <sup>2</sup> solid wire max. 2 x 1.5 mm <sup>2</sup> stranded wire with end thimble
Protection class (terminals)	(IP 20) Enclosure IP 40 IEC/EN 60529/ VDE 0470-1	(IP20) Enclosure IP40 IEC/EN 60529/ VDE 0470-1
Operational voltage	24VDC (+ 20 % / - 10 %)	24VDC (+ 20 % / - 10 %)
Fuse rating (supply)	1A (surge-resistant)	1A (surge-resistant)
Inputs	1 or 2 pairs SE-T/R Transmitter/Receiver	1 pair SE-T/R Transmitter/Receiver
Outputs	Changeover contacts	Normally open contacts
Safety contacts	11/14	13/14, 23/24
Signalling contacts	21/22/24	Semiconductor X1, Connection to internal ground U <sub>max</sub> . 36 V, I <sub>max</sub> . 50 mA
Max. switching capacity	max. 1000 VA	max. 1000 VA
Utilization category	AC-15; DC-13	AC-15; DC-13
Rated operational current/voltage I <sub>e</sub> / U <sub>e</sub>	2 A/230VAC; 2 A/24VDC	2 A/230VAC; 3 A/24VDC
Switching voltage	250V AC/DC	250V AC/DC
Max. switching current	6A (resistive load)	4A (resistive load)
Contact fuse rating	6A surge-resistant	4A surge-resistant
Mechanical life	2 x 10 <sup>7</sup> switching cycles	3 x 10 <sup>7</sup> switching cycles
Readiness time	Max. 300ms	Approx. 32ms
Switch-on delay	Max. 300ms	Approx. 32ms
Switch-off delay	Typically 15ms	Typically 15ms
Ambient temperature	+5 °C to +55 °C	+5 °C to +55 °C
Shock resistant	< 5g / 33Hz (VDE 0160)	< 5g / 33Hz (VDE 0160)
Interference	According to EMC Directive	According to EMC Directive
Weight Approx.	0.18kg	Approx. 0.2kg
Clearance and creepage distances	Degree of soiling 2 to VDE 0160 Overvoltage category III / 4kV to VDE 0160	Degree of soiling 2 to VDE 0160 Overvoltage category III / 4kV to VDE 0160
Power consumption	< 4 W	< 4 W

**Note:** Maximum distance to controller: 200m. Use 20AWG to extend bumper leads to safety controller.

# SERIES SE TECHNICAL DATA

## SE 304C



Electrical Specification	SE - 304C
<b>Standards</b>	EN 1760-2
<b>Safety Control Category</b>	3 to EN954-1
<b>Enclosure</b>	Thermoplastic
<b>Mounting</b>	DIN rail EN50 022
<b>Screwterminals</b>	Max. 2x2.5mm <sup>2</sup> solid wire Max. 2x1.5mm <sup>2</sup> stranded with end thimble
<b>Protection class (terminals)</b>	(IP20) Enclosure IP40 IEC/EN 60529/VDE 0470-1
<b>Operating voltage</b>	24VDC (+20%/-10%) 24VAC (+10%/-10%)
<b>Fuse rating (supply)</b>	1A (Slow-blow)
<b>Inputs</b>	1 to 4 pairs SE-T/R Transmitter/Receiver
<b>Outputs</b>	NO contact
<b>Safety contacts</b>	13/14
<b>Signalling contacts</b>	Semi-conductor XI, I <sub>max</sub> . 50 mA
<b>Max. switching capacity</b>	Max. 1500VA
<b>Utilization category</b>	AC-15, DC-13
<b>Rated operational current/voltage</b>	2A/230VAC, 2A/24VDC
<b>Switching voltage</b>	250VAC/60VDC
<b>Max. switching current</b>	2A
<b>Mechanical life</b>	>10 <sup>7</sup> switching cycles
<b>Switch-off delay</b>	Typically 17ms
<b>Ambient temperature</b>	+5°C to +55°C
<b>Shock resistant</b>	<5g/33Hz (VDE 0160)
<b>Interference</b>	According to EMC Directive
<b>Weight</b>	0.185 kg
<b>Power consumption</b>	<4W

# SERIES SE TECHNICAL DATA

## Typical Wiring Diagram

