

SRB-QS.1/SRB-QS.2

Safety relay array for emergency stop devices, interlocking devices and others

- ☞ **2-voltage version**
- ☞ **3 safety enabling outputs and 1 monitoring output**
- ☞ **Cross-short recognition**
- ☞ **Wipe contact**

Features

- Relay output: 3 NO, 1 NO, 1 wipe contact
(Auxiliary NC for monitoring must not be used in safety enabling circuits!)
- Reset, feedback loop
- Input for emergency stop or door monitoring
- LED for U_N
- Housing 90 mm, made of thermoplastic in accordance with UL-94-V-0, red RAL 3000
- DIN rail mounting (DIN EN 50 022)

Approvals



Front view

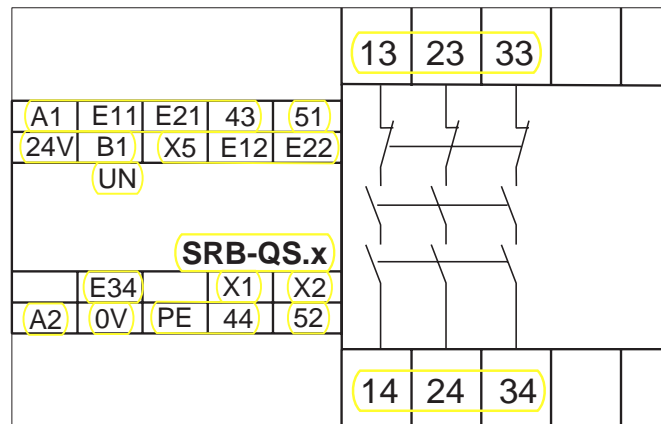

Product range

Type	Enabling outputs	Operating voltage	Part no.
SRB-QS.1	3 NO/1 NO/1 NC	24 VDC/VAC, 115 VAC	600 0590
SRB-QS.2	3 NO/1 NO/1 NC	24 VDC/VAC, 230 VAC	600 0600

SRB-QS.1/SRB-QS.2 (continued)

Wiring diagram

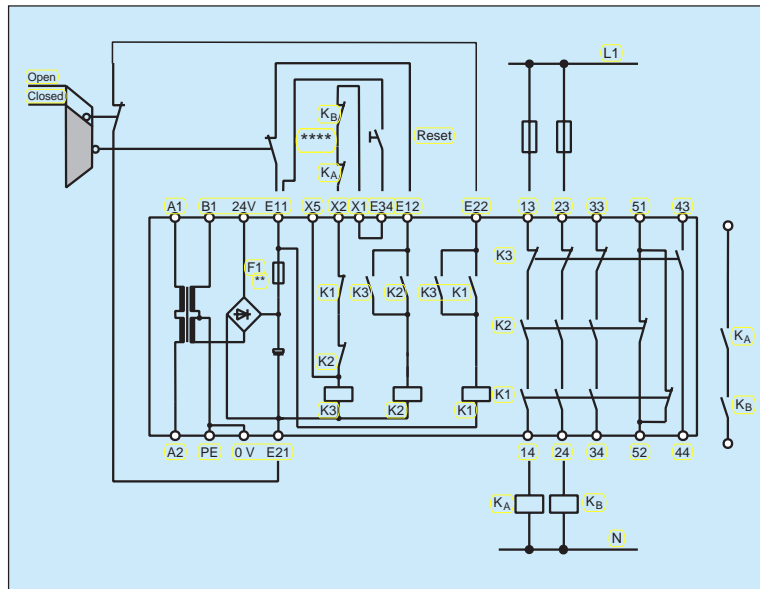

Example for dual-channel door monitoring using two limit switches (one with positive opening contacts) and external reset button.

Dual-channel output, suitable for contact reinforcement or contact multiplication, using relays or contactors with positively guided contacts.

**** (= Feedback loop)

Wire breakage and earth leakage in the monitoring circuits are detected.

For further examples refer to page 132/133

Model specific Technical data

(refer to page 157 for general data)

Operating voltage	24 VDC $-15\%/+20\%$, residual ripple max. 10% 115 VAC $-15\%/+6\%$ (SRB-QS.1), 230 VAC $-15\%/+6\%$ (SRB-QS.2)
Frequency	50/60 Hz (for AC operating)
Fuse (power supply)	M 0.25 A/250 V (internal M 0.5 A/250 V)
Power consumption	max. 3.9 VA
Switching capacity (enabling contacts)	230 VAC, 6 A ohmic (inductive with suitable suppression)
Fuse (enabling contacts)	6 A slow blowing
Switching capacity (monitoring contacts)	24 VDC, 2 A ohmic (inductive with suitable suppression)
Fuse (monitoring contacts)	2 A slow blowing
Application category	AC 15/DC 13, DIN VDE 0660 Part 200
Pick-up delay	≤ 200 ms
Drop-out delay	≤ 30 ms
Contact material / contacts	AgCdO self cleaning, positively driven
Contact resistance	max. 100 mOhm when new
Air and creeping distances	DIN VDE 0110-1 (04.97), 4 kV/2
Connections	Self lifting screw terminals min. 0.5 qmm, max. 2.5 qmm
Dimensions	H/W/D 83 mm/90 mm/140 mm
Weight	700 g
Ambient operating temperature	$-25^{\circ}\text{C} \dots +45^{\circ}\text{C}$ (derating curve page 157)
Mechanical life	10^7 switching cycles
Terminal labeling	DIN EN 50 005/DIN 50 013

Wiring example: Input level

Dual-channel emergency stop switch according to EN 60 204-1.

Wire breakage and earth leakage in the emergency stop circuits are detected.

Cross-shorts in the emergency stop circuits are detected.

With external reset button.

Safety category 3 or 4 in accordance with EN 954-1.

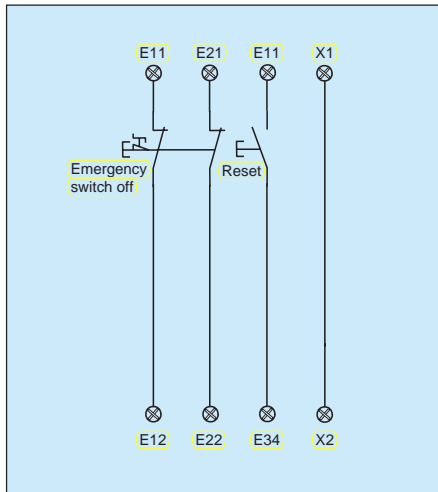

Advice:

Time window between channel 1 and channel 2 infinite.

WARNING: Auto reset after closing door.

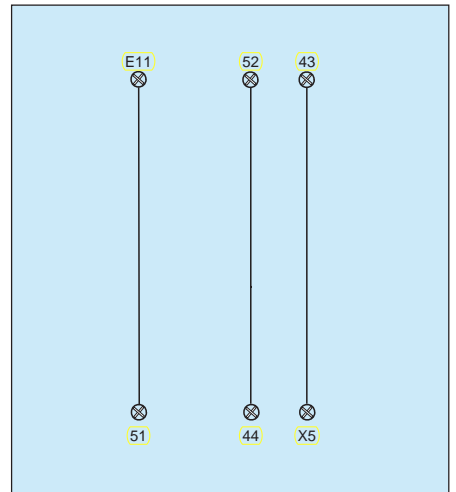

Wiring example: Input level

Dual-channel door monitoring according to EN 1088, one limit switch with positive opening contact.

Wire breakage and earth leakage in the door monitoring circuits are detected.

Cross-shorts in the door monitoring circuits are detected.

With external reset button for increased safety requirements.

Safety category 3 or 4 in accordance with EN 954-1.

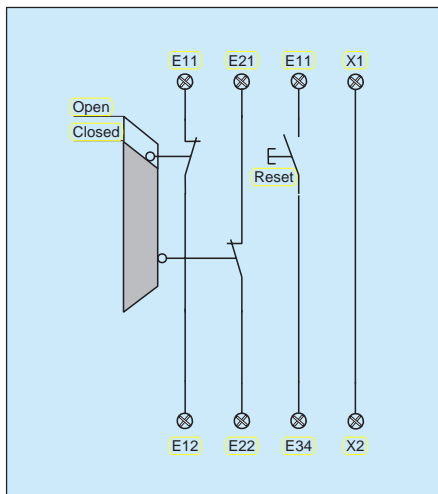

Wiring example: Input level

2-voltage-versions selectable:

115 VAC/24 V:
version SRB-QS.1

230 VAC/24 V:
version SRB-QS.2

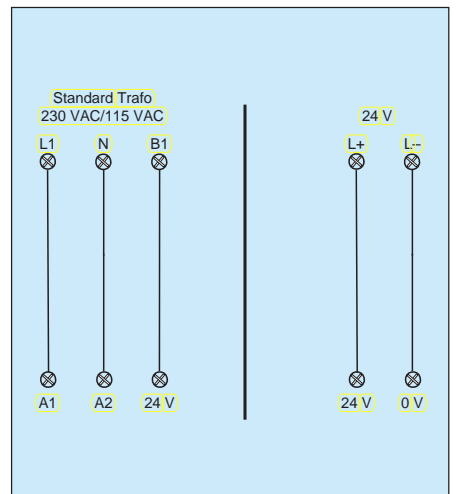

Wiring example: Input level

Start with trailing edge function.

Module is activated after release of the reset button.

This prevents tampering of the reset button which could lead to an automatic reset.

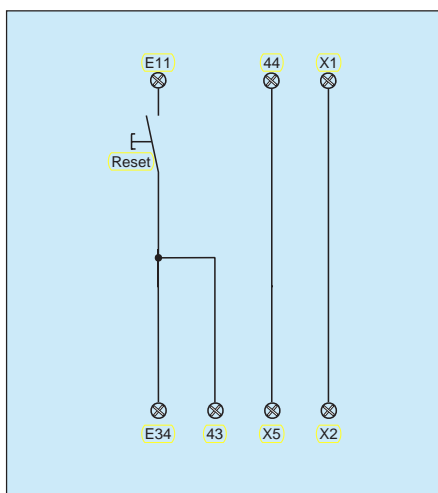

Advice:

LED (U_{LED}) is only ON if triggering circuits are activated.

**Wiring example:
Power level**

Single-channel output

Suitable for contact reinforcement or contact multiplication, using relays or contactors with positively guided contacts.

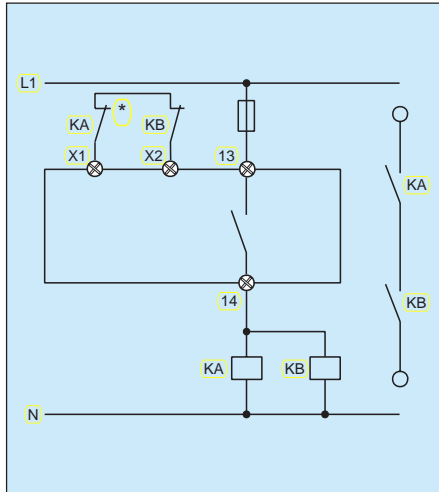

* Feedback loop

**Wiring example:
Power level**

Dual-channel output

Suitable for contact reinforcement or contact multiplication, using relays or contactors with positively guided contacts.

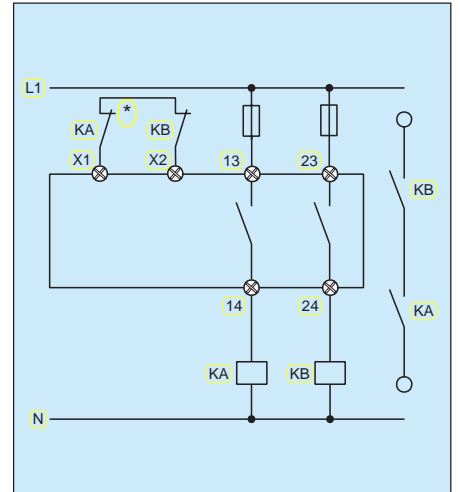

* Feedback loop

