

SERIES TESF

Adjustable Switching Point Hinged Interlock Switch



Description

The TESF Series is designed for use with movable hinged machine guards which must be closed for operator safety. Their tamper-resistant design and positive-opening NC contacts provide a significantly higher level of safety than conventional, spring-driven limit switches or proximity switches often used to monitor hinged guard positions.

Their compact, low-profile design and IP65 rating make them ideal for interlocking hinged safety guards in industrial environments. Designed to mount directly on the hinged guard and its stationary frame, it is easy to install on a wide range of extruded aluminum guard sizes and other guard styles.

Among its unique features is its ability to adjust the switching point in the field to meet specific application requirements.* Once adjusted, the switching point is easily permanently locked to prevent further adjustment by unauthorized personnel. In addition it features top or bottom cable entries, 1 NO or 2 NO and 2 NC contacts, designs suitable for inside- or outside-guard mounting, and the ability to open a full 180°.

*Note: The unit is delivered factory set with a switching point at a 3° opening angle with positive-break occurring at 5°. Please note that with use this factory-set point may increase 2° during lifetime. This should be considered ... especially where finger or hand protection is desired.

Operation

The installed TESF features two integral contact blocks ... each featuring a NO and a NC contacts. NC contacts are positive-opening, while the NO contact(s) may be used for signaling purposes. The electromechanical switch elements are actuated when the hinged guard is opened to the user's desired switching position (angle of opening). At this point the unit's positive-break, normally-closed contacts are forced to open by a direct (non-resilient) actuating mechanism, while the normally-open contacts close. The opening of the positive-break NC contacts ensure circuit interruption and machine stoppage. Machine restart is not possible while the guard remains opened.

Features & Benefits

- **Tamper-resistant ...** integral switch elements and actuator prevent bypassing.
- **“Positive-break” NC contacts ...** ensure circuit interruption when guard is opened to user's desired switching position (angle of opening).
- **User-selectable switching point ...** makes unit suitable for a wide range of applications.
- **Models available for inside-of-guard or front-of-guard mounting ...** for application versatility.
- **Choice of top or bottom cable entry ...** for installation flexibility.
- **Permits wide guard opening ...** up to 180°.
- **Splash-proof design ...** meets IP65 environmental requirements.
- **Slotted mounting holes ...** permit installation to most 30mm to 60mm aluminum profiles.
- **Rugged construction ...** tolerates mechanical abuse and hostile environments.
- **Meets rigid safety standards ...** UL, CSA, & BG (in preparation).

AVAILABLE STANDARD MODELS

(Includes hinge switch assembly and additional hinge)

Part Number (Contacts)	Description	Type Connections
TESF/O (2NO & 2NC)	For front installation with factory set switching point at 3°	Screw terminals
TESF/180 (2NO & 2NC)	For inside installation with factory set switching point at 3°	Screw terminals
TESF/U (2NO & 2NC)	For front or inside installation with user adjustable switching point	Screw terminals
TESF/ST24.1PE/U (1NO & 2NC)	For front or inside installation with user adjustable switching point	24VDC Quick disconnect (bottom entry)
TESF/ST24.2PE/U (1NO & 2NC)	For front or inside installation with user adjustable switching point	24VDC Quick disconnect (top entry)
TESF/ST24.1PE/O (1NO & 2NC)	For front installation with factory set switching point at 3°	24VDC Quick disconnect (bottom entry)
TESF/ST24.2PE/O (1NO & 2NC)	For front installation with factory set switching point at 3°	24VDC Quick disconnect (top entry)
TESF/ST24.1PE/180 (1NO & 2NC)	For inside installation with factory set switching point at 3°	24VDC Quick disconnect (bottom entry)
TESF/ST24.2PE/180 (1NO & 2NC)	For inside installation with factory set switching point at 3°	24VDC Quick disconnect (top entry)
TESFA/180 (2NO & 2NC)	Hinged interlock with integral fixed-to-movable guard frame alignment aid. For inside installation with factory set switching point at 3°	Screw terminals
TESFA/ST24.1PE/180 (1NO & 2NC)	Hinged interlock with integral fixed-to-movable guard frame alignment aid. For inside installation with factory set switching point at 3°	24VDC Quick disconnect (bottom entry)
TESFA/ST24.2PE/180 (1NO & 2NC)	Hinged interlock with integral fixed-to-movable guard frame alignment aid. For inside installation with factory set switching point at 3°	24VDC Quick disconnect (top entry)

A 22 mm gap between the door and door frame is required for models with the alignment aid and for inside mount models.

AVAILABLE ACCESSORIES

Part Number	Description
TESF/S	Additional hinge assembly (without alignment aid)
TESFA/S	Additional hinge assembly (with integral alignment aid)
TESF-14	Switching Point Adjustment Tool

SERIES TESF TECHNICAL DATA

MECHANICAL SPECIFICATIONS

Materials of Construction	Housing & hinge: die-cast zinc Cover: thermoplastic
Factory Set Displacement Angle for NC Contact Opening and NO Contact Closing	3°
Degree of Protection	IP65
Maximum Opening Angle	180°
Operating Temperature	-10°F to +148°F
Mechanical Life	> 10 ⁶ Operations (minimum)
Mechanical Loading Capacity (See dimensional drawings)	F1: 5000 N (110 lbs.) F2: 5000 N (110 lbs.) F3: 2000 N (45 lbs.)
Installed Position	Random
Operating Rate	1200 operations/hour (maximum)
Shock Tolerance	30g/18ms
Vibration Tolerance	20g, 10 ... 200 Hz
Cable Entry	M16 x 1.5
Maximum Actuation Speed	180°/0.3 seconds
Conformity to Standards	UL, CSA, & BGIA (in preparation)

ELECTRICAL SPECIFICATIONS

Contacts	Silver-nickel, gold-plated
Contact Rating	2A/250 VAC (AC15) 1A/24 VDC (DC13)
Contact System	Cross Point System
Contact Force	1N per contact
Switching Action	Slow-acting, positive-break NC contacts
Short-Circuit Protection	2.0 A (Slow blow)
Rated Impulse Withstand Voltage	2.5 kV
Rated Insulation Voltage	250 VAC
Thermal Rated Current	2.5 A
Rated Operating Voltage	250 VAC
Switching of Small Loads	5 VDC/1 mA (minimum)
Electrical Connections*	Screw terminals for 15AWG maximum stranded wire or 24 VDC quick disconnect: M12 (8 Pole)



Front installation:
Guard closed



Front installation:
Guard opened through 180°



Inside installation:
Guard closed



Inside installation:
Guard opened through 180°

CONNECTOR PIN CONFIGURATION

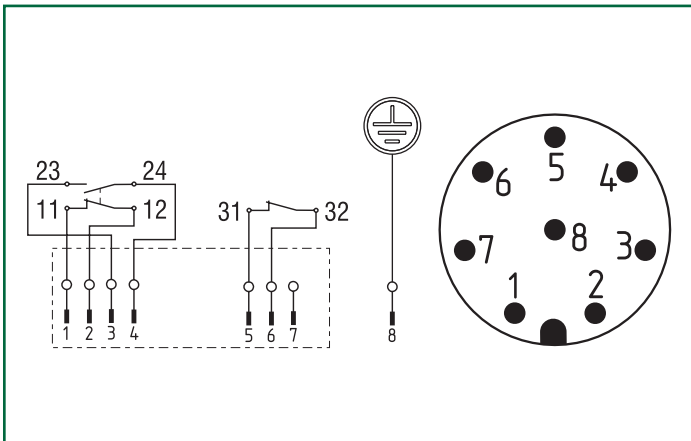

SWITCHING DIAGRAMS & CONTACT SCHEMATICS

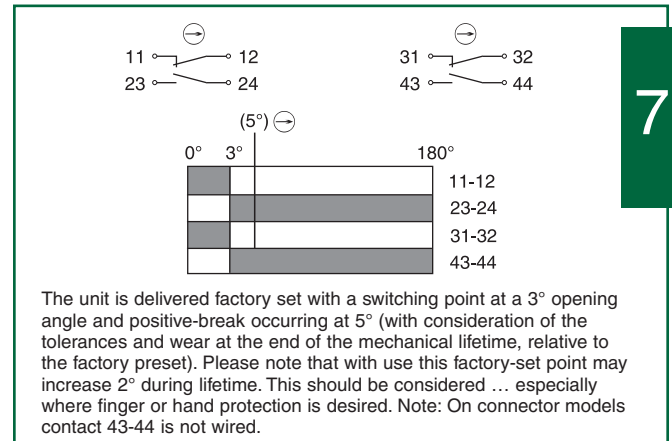

SERIES TESF TECHNICAL DATA

DIMENSIONS (SWITCH & HINGE ASSEMBLY SHOWN WITH ALIGNMENT AIDS)

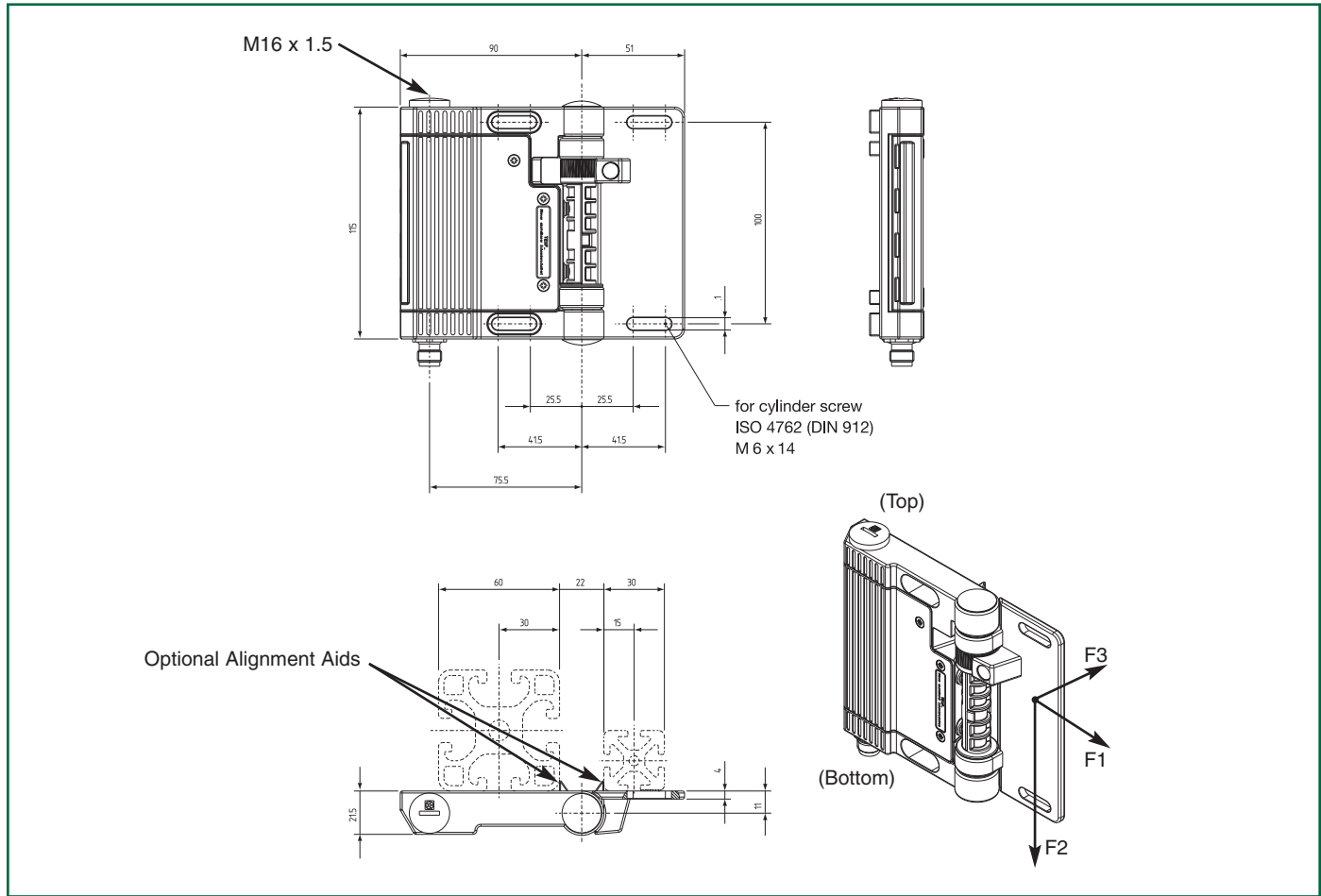

DIMENSIONS (ADDITIONAL HINGE SHOWN WITH ALIGNMENT AIDS)

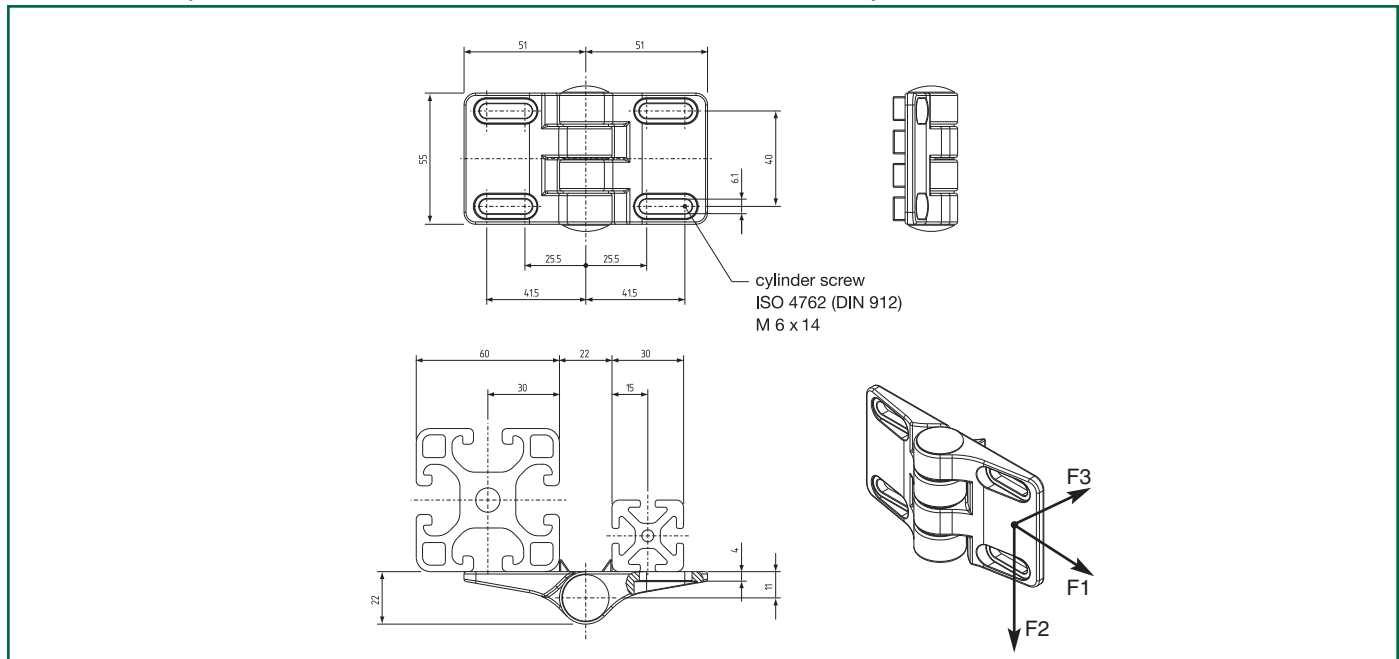

SERIES TESF TECHNICAL DATA

DETERMINING THE DOOR GAP AS DEPENDENT ON OPENING ANGLE, DOOR WIDTH AND OVERLAP

Opening angle "β" of the door	3°	4°	5°	6°	7°	8°	9°	10°
Door width "C" in mm	Door gap "D" in millimeters with overlap "B" = 0 mm							
100	5.2	7.0	8.7	10.4	12.2	13.9	15.6	17.4
150	7.8	10.5	13.1	15.7	18.3	20.9	23.5	26.0
200	10.5	13.9	17.4	20.9	24.4	27.8	31.3	34.7
250	13.1	17.4	21.8	26.1	30.5	34.8	39.1	43.3
300	15.7	20.9	26.1	31.3	36.5	41.7	46.9	52.1
350	18.3	24.4	30.5	36.6	42.6	48.7	54.7	60.7
400	20.9	27.9	34.8	41.8	48.7	55.6	62.5	69.4
450	23.5	31.4	39.2	47.0	54.8	62.6	70.4	78.1
500	26.2	34.9	43.6	52.2	60.9	69.6	78.2	86.8
550	28.8	38.3	47.9	57.5	67.0	76.5	86.0	95.5
600	31.4	41.8	52.3	62.7	73.1	83.5	93.8	104.1
650	34.0	45.3	56.6	67.9	79.2	90.4	101.6	112.8
700	36.6	48.8	61.0	73.1	85.3	97.4	109.4	121.5
750	39.2	52.3	65.3	78.4	91.4	104.3	117.3	130.2
800	41.8	55.8	69.7	83.6	97.4	111.3	125.1	138.8
850	44.5	59.3	74.0	88.8	103.5	118.2	132.9	147.5
900	47.1	62.7	78.4	94.0	109.6	125.2	140.7	156.2
950	49.7	66.2	82.8	99.3	115.7	132.1	148.5	164.9
1,000	52.3	69.7	87.1	104.5	121.8	139.1	156.4	173.6
1,050	54.9	73.2	91.5	109.7	127.9	146.1	164.2	182.2
1,100	57.5	76.7	95.8	114.9	134.0	153.0	172.0	190.9
1,150	60.2	80.2	100.2	120.1	140.1	160.0	179.8	199.6
1,200	62.8	83.7	104.5	125.4	146.2	166.9	187.6	208.3
1,250	65.4	87.2	108.9	130.6	152.3	173.9	195.4	217.0
1,300	68.0	90.6	113.2	135.8	158.4	180.8	203.3	225.6
1,350	70.6	94.1	117.6	141.0	164.4	187.8	211.1	234.3
1,400	73.2	97.6	122.0	146.3	170.5	194.7	218.9	243.0
1,450	75.8	101.1	126.3	151.5	176.6	201.7	226.7	251.7
1,500	78.5	104.6	130.7	156.7	182.7	208.7	234.5	260.3

Calculation example

The actual door gap "D1" is calculated from the door gap "D" calculated according to the above table less the overlap of door and frame "B":

$$D1 = D - B$$

Example: A door made of 40 mm aluminium profile with a length of 950 mm is to be secured with a TESF. According to the technical data sheet the safety contact of the TESF opens at 3° in new state (5° at end of useful life). In new state a door gap of approx. 49.7 mm is derived from the above table. The actual door gap, calculated using the above formula $D1 = D - B$ produces $(49.7 - 40 = 9.7)$; $D1 = 9.7$ mm. At the end of useful life there is a door gap of approx. 82.8 mm and an actual door gap of $(82.8 - 40 = 42.8)$; $D1 = 42.8$ mm.

